

Ceremonials

Published by

THE GRAND LODGE OF INDIA

Freemason's Hall, Janpath

NEW DELHI - 110 001

Telephone : +91-11-2332 1956 / 2332 1949

Fax : +91-11-2332 0276

e-mail : glindia@nde.vsnl.net.in

Website : <http://www.masonindia.org>

PREFACE TO 2010 EDITION

Rituals form the core of Masonic activity. The basic rituals for the various degrees in Freemasonry, prevalent under the Grand Lodge of India, are detailed in the respective ritual books for each degree but as we are all aware, there are other rituals pertaining to different ceremonies which are used from time to time on certain special occasions. These have been put together in this “Book of Ceremonials”, which was brought out for the first time in the year 1992 and subsequently reprinted in 2004.

This reprint has attempted to amend some mistakes which have inadvertently crept into the earlier versions and at the same time, to make a beginning in maintaining an e-record of our rituals. My sincere thanks to RW Bro. K Ramabrahmam and his dedicated team of brethren from Visakhapatnam, who have made this possible and generated this valuable asset for the Grand Lodge of India.

Over a period of time our rituals have undergone some change and new rituals/variants of existing rituals for some specific occasions have been developed. On an ongoing basis, it will be our endeavour to update this book to include such developments, making this book the ultimate handbook of masonic ceremonies; one that every brother with an interest in the ritual should necessarily own.

New Delhi
28th April 2010

B Kamakoti
Grand Secretary

PREFACE TO SECOND EDITION

The book titled 'Ceremonials' was first brought out during the year 1992. The Board of General Purposes of the Grand Lodge of India had authorised the Procedures and Protocol Committee to make corrections of prima facie mistakes while bringing out a reprint of this Ceremonial Book.

The Committee has made the required corrections and in addition has introduced a few elaborate diagrams and has also incorporated the new option of a Memorial Service that has been recently introduced.

The Grand Lodge of India is thankful to R. W. Bro. G. L. Shahu and the members of the Procedure and Protocol Committee for their efforts in bringing out this edition which is bound to be useful to Brethren and Lodges.

New, Delhi
May, 2004

Dr. Harish Gupta
Grand Secretary

FOREWORD

In the publication of this revised edition of the Book of Ceremonials, the Procedure & Protocol Committee has made every effort to provide more details by way of general instructions, diagrams for Temple Arrangements, Seating Arrangements, Perambulations & Procedure. How far we have been successful is to be judged by you but I must express my gratitude to R. W. Bro. G. K. Selvarajan for working hard in preparing a manuscript first for the consideration of the Board and then for final printing after incorporating the various suggestions received at the board meeting on the 27th of Feb. 2004. I also thank V. W. Bro. R. R. Khandelwal for going through the various ceremonies in detail and putting forward valuable suggestions.

I thank M. W. The Grand Master, M. W. Bro. Arun Chintopanth, O.S.M. for going through the final manuscript before it was submitted for printing. If there are lapses the fault is mine; if you are satisfied the credit goes to the brethren mentioned above.

G. L. Shahu
Chairman
Procedure & Protocol Committee

CONTENTS

1. Laying of Foundation Stone	001
2. Centenary Celebrations – Craft	021
3. Centenary Celebrations - Royal Arch Chapter	038
4. Centenary Celebrations - Mark Lodge	053
5. Centenary Celebrations - R.A.M. Lodge	068
6. Consecration of a Lodge	077
7. Consecration of a Royal Arch Chapter	101
8. Consecration of a Mark Lodge	126
9. Consecration of a R.A.M. Lodge	151
10. Dedication of Lodge Banner	176
11. Dedication of Masonic Temple	186
12. Presentation of the Grand Lodge Jewel for 25/40/50/60 years as a Freemason in a Craft Lodge	206
13. Presentation of the Supreme Grand Chapter Jewel for 25/40/50/60 years as a Companion in a Royal Arch Chapter	212
14. Presentation of the Grand Mark Lodge Jewel for 25/40/50/60 Years as a Mark Master Mason in a Mark Lodge	218
15. Presentation of the Grand Mark Lodge Jewel for 25/40/50/60 Years as an Ark Mariner in an R.A.M. Lodge	224
16. Memorial Service (Option - 1)	230
17. Memorial Service (Option - 2)	248

CEREMONY OF LAYING THE FOUNDATION STONE OF A MASONIC TEMPLE

General Instructions:

1. The Diagrams give the general lay out of the arrangements at the site; the seating arrangement for M. W. The Grand Master and his participating officers, for the representatives of the Masonic Fraternity, and for the ladies, gentlemen and brethren; the position of tables and such other furniture for keeping cushions, consecrating vessels and Vs. of S.L.; and directions regarding how these should be arranged.
2. Cushions are required, one each for the phial containing coins, phial containing suitable souvenirs of the period, inscription plate, trowel, maul, plumb rule, level, square, building plans and for each of the five Vs. of S.L; numbering 14 in all. The four consecrating vessels shall have been previously placed on the long table kept for that purpose.
3. The Foundation Stone shall be laid at the North-East Corner of the premises.
4. The Pit, Tripod, Pulley and the Foundation Stone shall, as far as possible, be as per the details in the diagram.
5. R. W. The Regional Grand Master, the W. Master of the Lodge and the Chairman of the Building Committee shall be part of the Grand Lodge Procession.

6. Brethren should robe themselves before proceeding to their seats at the Ceremonial Site.
7. Brethren other than those in the Procession and Ladies and Gentlemen should take their seats 15 Minutes before the Ceremony is scheduled to commence.
8. All should stand when:
 - a) M. W. The Grand Master and his Officers in the Procession enter and retire before and after the Ceremony respectively.
 - b) The Vs of S.L. are opened and closed
 - c) The Grand Chaplain renders the Prayers
 - d) The Ceremony of Laying of Foundation Stone is conducted by M. W. The Grand Master
 - e) The National Anthem is sung.

ORDER OF PROCEDURE

1. The G. D. of C. assisted by his Deputy and Assistant will form the Procession, according to the G.L. rank of each brother with juniors in the front and seniors at the rear. Apart from the Consecration Vessels, all the other items should be carried on cushions - 14 in all.
2. The Deputation from Grand Lodge and the Management Committee of the Masonic Fraternity of the Lodge will arrive in procession at the site.

3. As the Procession arrives everyone will stand & resume their seats only after M. W. The Grand Master takes his seat.
4. M. W. The Grand Master and the Officers accompanying him will be conducted to their seats by the G. D. of C. and his Deputy.
5. Bearers of W.T.s will place the W.T.s on the long table.
6. The Superintendent of Works shall place the plan on the table.
7. Grand Chaplain followed by G. Brs. of Vs of S.L. will form in front of M. W. The G. M. The G. D. of C. assisted by his Deputy will take the Vs. of S.L. and place them on the Altar.
8. The G. D. of C., assisted by his Deputy will take the cushions from Grand Secretary and Grand Treasurer and place them on the long table.
9. As and when Brethren are relieved of their cushions, they will proceed to their allotted seats.
10. The Vs. of S.L. will be opened by the G. D. of C. All brethren and visitors will stand.
11. The W.M. of the Lodge will address the assembly and invite M.W. The G.M. to lay the Foundation Stone.

12. M.W. The Grand Master may, if he wishes, give an introductory address on the nature and purpose of the Institution of Freemasonry.
13. The G.D. of C., assisted by his Deputy will escort M.W. The Grand Master, and the Dy. G.M. to the Foundation Stone pit.
14. M.W. The G.M. directs that the Stone be raised. The Stone is raised with a block and tackle by the Clerk of Works and the Foreman in three distinct stages.
15. M.W. The G.M. addresses the meeting: "Ladies, Gentlemen and Brethren assembled here today to behold this ceremony, know all of you that we the lawful Masons, true and faithful to the laws of our country; and established of old with peace and honour in most countries, and engaged by solemn obligations to erect magnificent buildings to be serviceable to the Brethren and to the Glory of God, the G.A.O.T.U..

We are here assembled today, in the presence of you all, to assist in laying in ancient form, the Foundation Stone of this Building as a house for Masonry in general and for the members of Lodge _____ No. _____ in particular, which, we pray to God, may prosper by becoming a place of concord for good men and for the promotion of Harmony and Brotherly Love throughout the World, until

time with us shall be no more. Before I proceed with laying the Foundation Stone, I call upon the Chaplain to give the Opening Prayer.”

G. D. of C.: To order, Ladies, Gentlemen & Brethren. *(All visitors and Brethren will stand while the Grand Chaplain gives the prayer.)*

16. Grand Chaplain: “Almighty and Eternal God, G.A.O.T.U., who dost from Thy Throne behold all dwellers upon Earth, direct us in all our doings with Thy most gracious favour, and further us with Thy continual help, that in all our works begun, continued and ended in Thee, we may glorify Thy Holy Name”.

Omnes: S.M.I.B.

17. Grand Treasurer, Grand Registrar and Grand Secretary will form up facing MW The G.M..

(The G.D. of C. and his Deputy will have the phials ready on cushions)

18. M.W. The G.M. proceeds to the Stone and calls upon those bearing the phials, to announce the contents and place them in the cavity.
19. The Grand Treasurer will place the phial in the cavity after announcing its contents and return to his seat. The phial should normally contain a full set of the latest coinage.

20. The Grand Registrar will place the second phial in the cavity after announcing its contents and return to his seat. The phial should contain suitable souvenirs of the date, eg. a copy of the local paper, Invitation for the Foundation Stone Laying Ceremony, Latest Summons of the Lodge, the current appeal for funds and other appropriate literature, such as an order of procedure for the Ceremony.

21. M.W. The G.M. will ask the Grand Secretary to read the inscription on the plate and cover the cavity with the plate.

Grand Secretary does so and returns to his seat, The inscription on the plate, if any, should record the same information as is displayed on the Stone itself, together with the names of the Architect and Builder.

22. A workman with cement on a board will be conducted to the right of M.W. The G.M. The G. Bearers of W.Ts. will form up on the left of the M.W. The G.M. who will be given the W.T.s on cushions by the Assistant G. D. of C.

23. M.W. The G.M. is offered the Trowel by its Bearer; he takes it and spreads cement on the lower stone, i.e., to cover the plate.

The mortar board is brought forward at the same time as the MW The G.M. is offered the Trowel. After use, M.W. The G.M. places the Trowel back on the cushion and takes the Maul.

24. M.W. The G.M. will direct that the Stone be lowered. The Stone is then lowered into place in three distinct stages and adjusted by MW The G.M. with the Maul. MW The G.M. adjusts the Stone by striking it at each of the four corners with the Maul saying:

“With Temperance, Fortitude, Prudence and Justice may our work be well founded”.

He then returns the Maul to its Bearer.

25. MW The G.M.: “Brother Junior Grand Warden, you will apply the Plumb Rule to prove the Stone”.

The Junior Grand Warden proves the Stone plumb and reports: “M.W. The G.M., I find the Stone perfect and trustworthy; the Craftsmen have done their duty”.

The J.G.W. replaces the P.R. on the Cushion and proceeds to his place.

26. M.W. The G.M. says : “Brother Senior Grand Warden, you will apply the Level to prove the Stone”

The Senior Grand Warden proves the Stone level and reports: "M.W. The G.M., I find the Stone to be well founded; the Craftsmen have done their duty".

The S.G.W. replaces the Level on the Cushion and proceeds to his place.

27. M.W. The G.M.: "Brother Deputy Grand Master, you will prove the Stone Square".

The Deputy Grand Master proves the Stone Square by applying the Square to one of its angles and reports : "M.W. The G.M., I have applied the Square, and find the Stone to be true; the Craftsmen have done their duty".

The Dy. G.M. replaces the square on the Cushion.

28. The Dy. Grand Master presents the Maul to M.W. The G.M. who receives it, and then says: "Having full confidence in your skill in the Royal Art, it now remains with me to complete the work".

He then strikes the Stone three times with the Maul, saying : "By the power in me vested and in the name of the G.A.O.T.U., I declare this Stone well and truly laid and in accordance with Antient Rules of Architecture".

(MW The G.M. returns the Maul to the Dy. G.M. who replaces it to the cushion. Dy. G. D. of C. takes the cushions with the W.Ts. and returns them to their places and proceeds to his seat. Bearers of W.T.s return to their seats as and when they are relieved of their cushions.)

29. The Grand Superintendent of Works will present the plans for the inspection and approval of M.W. The G.M. saying: "M.W. The G.M., I present to you the plans of the proposed building for your inspection and approval".

M.W. The G.M. takes the plans in his hands saying: "I will do so with pleasure." He returns the plans after inspection saying: "With the implements of our Craft and with these instructions, may there be raised a superstructure, perfect in its parts and honourable to its builders".

30. The G. D. of C. hands the Vessel containing Corn to M.W. The G.M. saying: "M.W. The Grand Master, I present to you corn, the sacred emblem of Plenty".

31. M.W. The G.M. scatters Corn on the Stone saying: "I scatter Corn on this Stone, the emblem of Plenty; May the all-bounteous Creator of the Universe shower down His Choicest blessings on the members of this Community and all who shall assemble in this building to the Glory of the Most High, until time with us shall be no more".

G. D. of C.: Brethren will now sing together.

Omnes: Glory be to God on High.

32. The G. D. of C. hands the Vessel containing Wine to the M.W. The G.M. saying, "M.W. The Grand Master, I present to you Wine, the sacred emblem of Joy and Cheerfulness".
33. M.W. The G.M. pours Wine on the Stone, saying: "I pour Wine on this Stone, the emblem of Joy and Cheerfulness and may He Whose Name is Love, grant that we may be all of one heart and mind and may we ever dwell together in peace and unity".

G. D. of C.: Brethren will now sing together.

Omnes: Glory be to God on High.

34. G. D. of C. hands the Vessel containing Oil to M.W. The G.M. saying: "MW The Grand Master, I present to you Oil, the Sacred emblem of Charity".
35. M.W. The G.M. pours Oil on the Stone saying, "I pour Oil on this Stone, the emblem of Charity and may God give us grateful hearts and may we be ever ready, cheerfully to relieve the wants of others".

G. D. of C.: Brethren will now sing together.

Omnes: Glory be to God on High.

36. G. D. of C. hands the Vessel contained Salt to M.W. The G.M. saying: "M.W. The Grand Master, I present to you Salt, the sacred emblem of Hospitality and Friendship".

37. M.W. The G.M. sprinkles Salt on the Stone saying, "I sprinkle Salt on this Stone, the emblem of Hospitality and Friendship and may the all-bounteous Author of Nature bless this town, State, Region and Republic at large with abundance of Corn, Wine and Oil and all necessities, comforts and conveniences of life. And may the Almighty Architect of the Universe look down with benignity upon our present undertaking and crown the edifice of which we have now laid the foundation, with every success".

G. D. of C.: Brethren will now sing together.

Omnes: Glory be to God on High.

G. D. of C.: To order, Ladies, Gentlemen and Brethren.

(All visitors and Brethren will stand with Sn. of R. while the Grand Chaplain gives the Prayer and Benediction.)

PRAYER

38. Grand Chaplain: "Bless, we beseech Thee, the work we have this day begun in Thy name. May the Edifice about to be erected on this Foundation Stone be completed to Thy Honour and Glory, and may those who shall hereafter use this building, dedicate and devote their lives to Thy Service, and evermore praise and magnify Thy Most Holy Name".

BENEDICTION

39. Grand Chaplain: "May the G.A.O.T.U. bless, preserve and keep us evermore; may He lift up the light of His Countenance upon us, and give us peace, now and for evermore".

Omnes: S.M.I.B.

(All visitors and Brethren resume their seats.)

40. G. D. of C., assisted by his Deputy escorts M.W. The G.M. and R.W. The Dy. G.M. to their seats.
41. R.W. The Regional Grand Master may address the Assembly.
42. M.W. The Grand Master may address the Assembly.
43. The Grand Secretary proposes a vote of thanks.
44. G. D. of C. calls everyone to order.
45. The Vs. of S.L. are closed by the G. D. of C.
46. After the National Anthem, the G. D. of C. requests everybody to be seated and forms the retiring Procession.
47. G. D. of C. calls everyone to order while the Procession retires, saying: "Ladies, Gentlemen and Brethren kindly be upstanding while M.W. The G.M. retires."

(Arrangements as per Annexure and Diagrams)

ANNEXURE

ARRANGEMENTS:

1. SEATING ARRANGEMENTS (SEE DIAGRAM A):
 - a. Entire area has to be leveled and cleaned.
 - b. 14 chairs to face South with a Table. Seats to be provided for other Officers as given in Diagram A.
 - c. Altar with a Kneeling Stool
 - d. Adequate number of seats for Ladies and Gentlemen; and Brethren separated by a 10 ft. wide passage in the Centre, the visitors to face North.
2. PITS AND TRIPOD FOR LAYING FOUNDATION STONE (SEE DIAGRAM B):
 - a. A Foundation Pit to be made at the North East corner of the land with a dimension of about 6 ft. length and 6ft. breadth and 2 ft. depth.
 - b. Inner Pit of a dimension of about 1 ft. 6 inches length and 1ft. 6 inches breadth with a depth of about 1 ft.
 - c. Steps to be provided in the Outer Pit to descend from the Ground level to Inner Pit.
3. FOUNDATION STONE (ROUGH GRANITE OR RCC SLAB):
 - a. Foundation Stone of a size of 1 ft. 6 inches length and 1 ft. 6 inches breadth with a thickness of about 2 or 3 inches.

- b. The Foundation Stone should appropriately fit into Inner Pit.

4. TRIPOD:

- a. A Tripod to be erected with a thick rope and a Pulley.
- b. One end of the Rope to be tied with the Foundation Stone. (When the Rope is released, the Foundation Stone should suitably fit into the Inner Pit).
- c. Adequate space should be provided in front of the Outer Pit to enable the Visitors to come closer and witness the Ceremony.
- d. A Long Table to be provided behind the Outer Pit for placing the Cushions, Vessels and Working Tools.

5. AREA FOR REFRESHMENTS. IF ANY:

Refreshment Area, if any, to be provided at the South West End of the Land.

6. GENERAL:

- a. Adequate Lighting arrangements to be made.
- b. Mike and Sound System.
- c. Video Filming, if necessary.
- d. Reserved area for the Press in the Visitors' Area.
- e. Mortar Board, Cement, Sand, Trowel, Water, etc.

7. ROBING AREA:

- a. The Robing Area covered with shamiana / cloth walls to be provided at the South East part of the land.
- b. Adequate number of tables to be provided inside the Robing Area for placing Apron boxes, Cushions, Working Tools, etc.

8. A PLAQUE/POLISHED GRANITE STONE:

A Plaque / Polished Granite Stone with the following Inscription is to be made:

LODGE _____ NO. _____	
THIS FOUNDATION STONE	
FOR THE MASONIC TEMPLE LAID BY	
MW BRO. _____	
MW THE GRAND MASTER	
GRAND LODGE OF INDIA	
ON _____	THE _____ AT _____
IN THE PRESENCE OF	
W BRO. _____	RW BRO. _____
W.M of Lodge _____	RW The R G M
	Of RGL _____ India.
Architects _____	
Builder _____	

9. ITEMS REQUIRED:

- a. Building plan for construction of the building.
- b. 14 Cushions for placing the Phials, Volumes of Sacred Law, Working Tools, Plan, etc.
- c. One Phial (Plastic with Cover) to contain Rupee Notes of Rs.100, Rs.50, Rs.20, Rs.10, Rs.5, Rs.2 and Re.1 and Coins of Rs.5, Rs.2, Re.1, 50p, 25p (whatever is available).
- d. One Phial to contain the Newspaper of the date, Souvenirs, Summons of the Lodge, Invitation for the Foundation Stone Laying ceremony, Directory of the Members of the Lodge, etc. (whatever is available).
- e. Five Vs. of S.L. preferably of equal size, Trowel, Maul, Plumb Rule, Level, Square.
- f. (Consecrating) Vessels with Corn, wine, oil and salt.

10. INSCRIPTION PLATE:

Inscription Plate (stainless steel preferable) of a size of about 1ft. 6 inches length and 1ft. 6 inches breadth to fit the Inner Pit with the same matter as contained in the Plaque described in item 8 above.

LODGE _____ NO. _____

THIS FOUNDATION STONE
FOR THE MASONIC TEMPLE
LAID BY

MW BRO _____

MW THE GRAND MASTER
GRAND LODGE OF INDIA

ON _____ THE _____ AT _____

IN THE PRESENCE OF

W BRO. _____ RW BRO. _____

W.M of Lodge _____ RW The R G M
Of RGL _____ India.

Architects _____

Builder _____

FOUNDATION STONE LAYING CEREMONY DIAGRAM 'A'

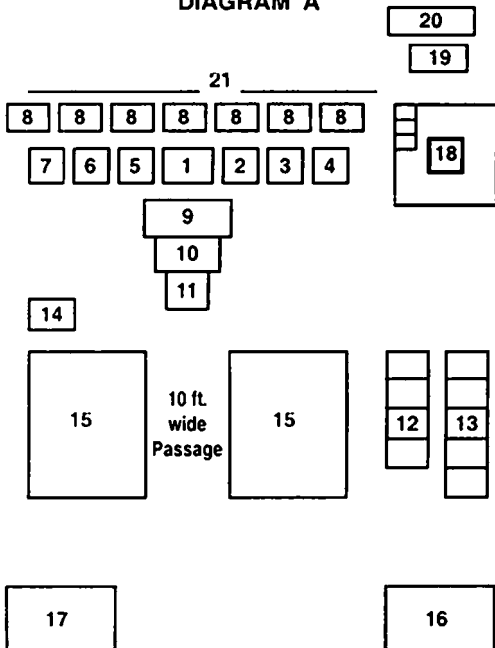

DETAILS OF DIAGRAM 'A'

1. MW The Grand Master
2. RW The Regional Grand Master
3. W Master of the Lodge
4. Chairman, Building Committee
5. RW The Deputy Grand Master
6. Senior Grand Warden
7. Junior Grand Warden
8. Seats for Grand Chaplain, Grand Treasurer, Grand Registrar, Grand Secretary, Grand Superintendent of Works, Grand Standard Bearers.
9. Table
10. Altar
11. Kneeling Stool
12. Seats for Grand Director of Ceremonies, Deputy Grand Director of Ceremonies, Grand Sword Bearer and Junior Grand Deacon.
13. Seats for 5 Grand Bearers of Vs of S.L.
14. Seat for Senior Grand Deacon
15. Chairs for Ladies, Gentlemen and Brethren
16. Robing Area
17. Area for Refreshments, if any.
18. Foundation Pits with Tripod (See Diagram 'B')
19. Plaque
20. Long Table
21. Banner if any

DIAGRAM 'B': FOUNDATION PITS WITH TRIPOD

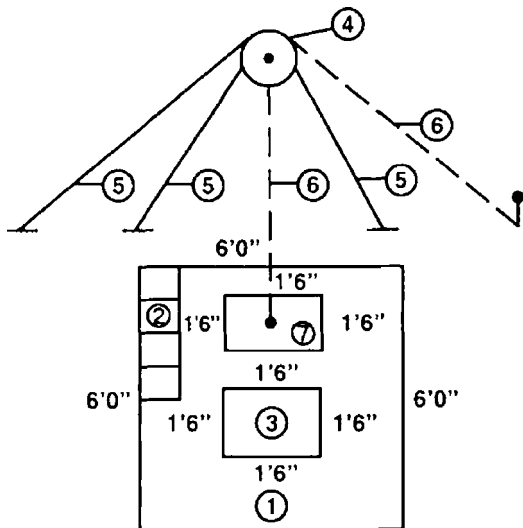

- | | | | |
|----|-----------|----|------------------|
| 1. | Outer pit | 5. | Tripod |
| 2. | Steps | 6. | Rope |
| 3. | Inner pit | 7. | Foundation Stone |
| 4. | Pulley | | |

**CENTENARY CELEBRATIONS (CRAFT)
OPENING HYMN**

Hail! Eternal, by Whose aid,
All created things were made,
Heaven and earth Thy vast design
Hear us Architect Divine.

May our work begun in Thee,
Ever blest with order be;
And may we when labours cease,
Part in harmony and peace.

By thy glorious Majesty,
By the trust we place in Thee,
By the Badge and Mystic Sign,
Hear us Architect Divine.

S.M.I.B.

1. To open the Lodge.
2. To read the Summons convening the Meeting.
3. To read and confirm the Minutes of the last Regular Meeting held on _____
4. To read and adopt the Minutes of the Lodge Committee, held if any.
5. To open the Lodge in the Second Degree after all E.As are requested to retire temporarily from the Lodge.

6. To open the Lodge in the Third Degree after all F.Cs. are requested to retire temporarily from the Lodge.
7. To receive R.W. The Regional Grand Master of The Regional Grand Lodge of _____ India, accompanied by his Deputation, welcome and greet him.
8. To receive M.W. The Grand Master and his Deputation, welcome and greet him.
9. To close the Lodge in the Third Degree and to readmit F.Cs.
10. To close the Lodge in the Second Degree and to readmit E.As.
11. Welcome address by the Worshipful Master
12. A brief history of the Lodge to be read
13. To handover charge of the Lodge to M.W. The Grand Master.

W.M.: "I now humbly invite and request MW Bro. _____, MW The Grand Master, our Chief Guest to take the chair to conduct the centenary celebrations and address brethren of the Lodge and the guests present here."

14. M.W. The Grand Master to take the Chair and appoint his Wardens.

M.W. The G.M.: "Bro. Grand Wardens, Bro. Grand Chaplain and Bro. Grand Secretary, you will take your respective places."

(The G.D. of C. and his Deputy escort the G.Ws., Grand Chaplain and Grand Secretary to their respective seats. The Grand Lodge Officers occupy their seats.)

15. M.W. The Grand Master to address the Lodge and call upon G. Chaplain to offer a Prayer.

Address by M.W. the Grand Master

M.W. The G.M.: Bro. Chaplain, I call upon you to invoke the blessings of the GAOTU.

G.D. of C.: Brethren will stand to order with the sign of R.

PRAYER

Grand Chaplain : O Thou Almighty and Eternal God, Thou Lord of Creation, Giver of Light and Life, in our hour of joy and sorrow, in our days of bliss and woe, we are taught to turn to you not only because it is our Masonic duty but because man hath need of Thee and his heart hungereth for Thee, for Thou art his daily sustenance, for Thou hast pointed out the true path to him, for Thou hast cast upon him the mantle of responsibilities and hast endowed him with the wisdom and ability to fulfill those responsibilities, for Thou hast given him the opportunity of creating greater fellowship through a richer and more meaningful brotherhood.

Thou hast given us this day the opportunity to receive Thy blessings and we would be remiss as men and we would fail as Masonic brethren if we did not turn to Thee for these blessings.

We, who have for our teachings the greatest teachings of all, find that they are worth nothing if we do not have good and responsible men to live these teachings and to spread them and to share them in all the things that we think and say and do.

Therefore, on this occasion of the Centenary Celebrations of our Lodge we humbly beseech Thy blessings upon our endeavours to make this Fraternity of ours the greatest and most significant Fraternity that is on the face of the earth. Guide us then, we ask in Thy Most Holy and Glorious Name.

Omnes: S.M.I.B.

G.D. of C.: Brethren, be seated.

16. M.W. The Grand Master to ask the Grand Secretary to read the Centenary Warrant.

M.W. The G.M.: Bro. Grand Secretary, you will read the Centenary Warrant. (*Grand Secretary reads the Warrant.*)

17. To recite the Scripture extracts from the Volumes of the Sacred Law.

M.W. The G.M.: W.Bro.....will read the passage from Shrimad Bhagavad Gita.

Shrimad Bhagavad Gita .. Chapter IX

Verses 16 to 19

अहं क्रतुरहं यज्ञः स्वधाहमहमौषधम् ।
गन्त्रो ह्यहमेवाज्यमहमग्निरहं हुतम् ॥ १ ६ ॥

Verse 16: I am the Kratu, I, the Yajna, I, the Svadha, I, the Aushadham, I, the mantra, I, the Ajyam, I, the fire, and I, the oblation.

पिताहमस्य जगतो माता धाता पितामहः
वेद्यं पवित्रमोंकार ऋक् साम यजुरेव च ॥ १ ७ ॥

Verse 17: I am the Father of this World, the Mother, the Sustainer, the Grand-father, the Purifier, the (one) thing to be known, (the syllable) Om, and also the Rik, Sama and Yajus.

गतिर्भर्ता प्रभुः साक्षी निवासः शरणं सहत् ।
प्रभवः प्रलयः स्थानं निधनं बीजमव्ययम् ॥ १ ८ ॥

Verse 18: The Goal, the Supporter, the Lord, the Witness, the Abode, the Refuge, the Friend, the Origin, the Dissolution, the Substratum, the Store-house, the Seed immutable.

तपाम्यहमहं वर्षं निगृह्णाम्पुत्सृजामि च ।
अमृतं चैव मृत्युश्च सदसच्चाहमर्जुन ॥ १ ९ ॥

Verse 19: As the Sun, I give heat: I withhold and send forth rain; I am immortality and also death; being and non-being am I, O Arjuna !

M.W. The G.M.: W. Bro.....will read the passage from the Holy Koran.



بِسْمِ اللَّهِ الرَّحْمَنِ الرَّحِيمِ

١- الْحَمْدُ لِلَّهِ رَبِّ الْعَالَمِينَ ۞

٢- الرَّحْمَنِ الرَّحِيمِ ۞

٣- مَلِكِ يَوْمِ الدِّينِ ۞

٤- إِيَّاكَ نَعْبُدُ وَإِيَّاكَ نَسْتَعِينُ ۞

٥- اهْدِنَا الصِّرَاطَ الْمُسْتَقِيمَ ۞

٦- صِرَاطَ الَّذِينَ أَنْعَمْتَ عَلَيْهِمْ ۞ غَيْرِ

٧- الْمَغْضُوبِ عَلَيْهِمْ وَلَا الضَّالِّينَ ۞

Praise be to God, the Cherisher and Sustainer of Worlds; Most Gracious, Most Merciful; Master of the Day of Judgement; Thee do we worship and Thine aid we seek. Show us the Right Path— The Path of those on whom Thou has bestowed Thy grace, not the path of those who have incurred Thy displeasure nor those who have gone astray.

M.W. The G.M.: W. Bro.will read the passage from Zend Avesta.

દાદર હોરમઝદ જરથોસ્ત કહે છે :-

હું છું સરજનહાર બચાવનાર રક્ષણહાર
પોષનાર જાણનાર વૃદ્ધી અને તંદુરસ્તી
બક્ષનાર આશ્રવ અહુર મઝદા અશો
ખોરેહ પુર દુર નેગહબાન સર્વ વ્યાપક
હું છું કીર્તીવાન પુર્ણરક્ષણહાર તારણહાર
બચાવનાર સર્વ વ્યાપી હું જ છું.

Then spoke Ahura-Mazda, "I am Existence itself, the one and only Reality. I am the Saviour, the Creator and the Guardian of the Universe, the Creator of all life, the Omniscient, the Righteous, the Soul within everybody, the All-seeing and the Far-seeing. I am the One who looks after everybody, I am the

Universal Donor and the Protector who protects everybody. I am the All-Knowing: I am the one who looks after the well-being of all. I am the One who never deceives and is undecieved. I am the perfect Architect and the Architect of the Universe, the Light Eternal.

M.W. The G.M.: W. Bro.....will read the passage from the Holy Bible.

The LORD is my shepherd; I shall not want.

He maketh me to lie down in green pastures; He leadeth me beside the still waters.

He restoreth my soul; He leadeth me in the Paths of righteousness for His name's sake.

Yea, though I walk through the valley of the shadow of death; I will fear no evil; for Thou art with me; Thy rod and thy staff, they conform me.

Thou preparest a table before me in the presence of mine enemies; Thou anointest my head with oil; my cup runneth over.

Surely goodness and mercy shall follow me all the days of my life; and I will dwell in the house of the LORD for ever.

M.W. The G.M.: W. Bro. will read passage from the Holy Granth Saheb.

ਸੋਰਠਿ ਮਹਲਾ ੫ ॥

ਸੋਈ ਕਰਾਇ ਜੋ ਤੁਧੁ ਭਾਵੈ ॥ ਮੋਹਿ ਸਿਆਣਪ ਕਛੁ ਨ ਆਵੈ ॥

ਹਮ ਬਾਰਿਕ ਤਉ ਸਰਣਾਈ ॥ ਪ੍ਰਭਿ ਆਪੇ ਪੈਜ ਰਖਾਈ ॥ ੧ ॥

ਮੇਰਾ ਮਾਤ ਪਿਤਾ ਹਰਿ ਰਾਇਆ ॥

ਕਰਿ ਕਿਰਪਾ ਪ੍ਰਿਤਪਾਲਣ ਲਾਗਾ ਕਰੀ ਤੇਰਾ ਕਰਾਇਆ ॥ ਰਹਾਉ ॥

ਜੀਅ ਜੰਤ ਤੇਰੇ ਧਾਰੇ ॥ ਪ੍ਰਭ ਡੋਰੀ ਹਾਥਿ ਤੁਮਾਰੇ ॥

ਜਿ ਕਰਾਵੈ ਸੋ ਕਰਣਾ ॥ ਨਾਨਕ ਦਾਸ ਤੇਰੀ ਸਰਣਾ ॥੨॥੨॥੨੧॥

O, Merciful Lord, I do Thy will,

My intelligence and my desires are of no use;

I am Thy son and am always at Thy mercy.

It is Thy goodwill and Thou can dispose of me as Thou likest.

We are Thy children and Thou art our Mother and Father.

Oh my Master, Thou art our Creator and Protector.

I feed on the milk of Thy Name and I do whatever is Thy will.

Thou art the Creator of the world and the reins are in Thy hands

Thou art my Guide, my Teacher and my Master,

Whatever is Thy will, I do accordingly.

18. To take the Oath of rededication.

M.W. The G.M.: Bro. D. of C., You will now place the W Master of the Lodge in front of the altar, the SW on his right and the JW on his left; the I.P.M. behind the W.M. and the past masters and the brethren of the Lodge behind the I.P.M. in rows of 4 each. I will now request the W Master to take the obligation of rededication.

G.D. of C.: Brethren, stand to order with the sign of R whilst the W Master kneels before the Altar. *(Done)*

W. Master: We, the Master, Officers and Members of Lodge _____ no. __ in the register of the Grand Lodge of Antient Free and Accepted Masons of India, in the presence of the Almighty Architect of the Universe and of this Worthy and Worshipful Lodge, do solemnly and sincerely promise that we shall sustain, uphold and transfer, pure and unsullied, the traditions of the order into which we have entered. By this solemn act of _____ rededication we pledge ourselves to strive to acquire wisdom and understanding and to practice the truly Masonic virtues of Brotherly Love, Relief and Truth. So help us Thou G.A.O.T.U. and keep us steadfast in this our solemn obligation of rededication.

Omnes: S.M.I.B.

WM rises but remains standing with the other brethren. (Sn. of R.)

M.W. The G.M.: Bro. Chaplain

PRAYER

Chap(*From his seat*): Brethren let us now invoke the threefold blessings of the Lord God of Heaven and Earth, in the South, in the West and in the East and pray that His favour vouchsafed to this Lodge, these 100 years may continue and increase to our joy and His Glory.

(From the South in front of the JW's pedestal):

May the G.A.O.T.U. who, through the years has so liberally provided for the spiritual and temporal needs of our brethren in this place, continue to pour forth His Bounty and make this Lodge rich in Brotherly Love, Benevolence and Charity to the Honour and Glory of His Most Holy Name.

(From the West in front of the SW's pedestal):

May the All Merciful God who through all these years has given our brethren strength and gladness in their quest for wisdom and truth, increase in us, and our successors, every grace and virtue that can adorn and beautify the human mind, to the Honour and Glory of His Most Holy Name.

(From the East and on the left of the W Master): May the Most Holy and Blessed favour fill our hearts with joy and

peace and in knowledge and in service. May He pour forth the oil of harmony and loving kindness upon every enterprise and undertaking and bring us all at length to the Temple of Perfection, to that House, not made with hands, eternal in the Heavens.

Omnes: S.M.I.B

G.D. of C.: W.M. and Brethren resume your seats. *(Done)*

19. Address of congratulations and relinquishment of the charge of the Lodge.

M.W. The Grand Master will give address of congratulations.

M.W. The Grand Master will hand over charge of the Lodge to the W.M.

G.D. of C.: Upstanding Brethren

(M.W. The G.M. hands over charge of the Lodge and resumes his seat)

G.D. of C.: Be seated, Brethren

20. W.M. to resume the Chair along with his Officers.

W. Master resumes charge of the Lodge.

G.D. of C.: W.M., may I have your permission to relieve the Grand Wardens, Grand Chaplain and Grand Secretary?

W.M.: Yes, you may. *(Done)*

21. Address of thanks to the MW The Grand Master for conducting the ceremony.

WM delivers address of thanks to M.W. The Grand Master for performing the ceremony.

22. To call the Roll of the Past Masters of and in the Lodge and applaud them..

W. Master: Brethren, I would be failing in my duty were I not to assure, as I do, all my Past Masters that we shall keep this, our Lodge, pure and unsullied from generation to generation and in so doing we should honour each one of them present here individually. I would request each of them to please rise and acknowledge our humble offering as our Bro. Secretary reads their names and the year when they were the Ruling Masters. And you, my Brethren, will please give an applause as each of them rises from his seat. Bro. Secretary, you will please read out the names of Past Masters of and in the Lodge present.

(As his name is called, each PM will rise, give the sign of 1^o and resume his seat. Brethren will give an applause as each PM rises from his seat.)

23. To elect Honorary Members (if any).
24. Release of the Centenary Jewel by M.W. The Grand Master.

W.M. requests M.W. The Grand Master to release the Centenary Jewel.

M.W. The Grand Master will release the Centenary Jewel.

25. W.M. to present the Centenary Jewels.

The W.M. presents the centenary jewel to M.W. the Grand Master, R.W. The Regional Grand Master and M.W. The Grand Master for the Central Masonic Library & Museum.

26. Distribution of the Centenary Jewel amongst the Brethren.

W.M. requests M.W. The Grand Master to distribute the Centenary Jewel to the Brethren concerned.

M.W. The Grand Master will distribute the Centenary Jewel among the Brethren of the Lodge.

27. Release of Centenary Souvenir.

W.M. requests M.W. The Grand Master to release the Centenary Souvenir.

M.W. The Grand Master will release the Centenary Souvenir.

28. W.M. to present Centenary Souvenir copies to M.W. The Grand Master, R.W. The Regional Grand Master and the Grand and Regional Grand Officers.

W.M. presents copies of Centenary Souvenir to M.W. The Grand Master, R.W. The R.G.M. and their Officers.

29. Address of Thanks by W.M. to M.W. The G.M. and R.W.
The R.G.M.

W.M.: Address of Thanks.

R.G.M. will give thanks and say a few words.

30. W. Bro. Chaplain to offer a Thanks giving Prayer.

Thanksgiving Prayer

W. Bro. Chaplain of the Lodge offers a Thanksgiving Prayer
(Brethren to stand to order with the sign or R):

Almighty God, our Father, as we come to the close of these Celebrations, as ever our thoughts turn to Thee. Though we have in our hearts a sense of accomplishment, we seek Thy guidance and direction for there is much yet to be done. We are grateful to Thee for all that has transpired here and we pray for strength to accomplish the task that Thou hast set before us. We have received good counsel from men who have in their hearts the Love of God and a concern for the Fraternity. Grant us wisdom to heed their counsel and ability to emulate their mode of living to set a good example of Masonry in our communities in every area of our lives and not just in our Lodge Temples. Strengthen our hearts for an abiding belief in Thee O God and grant that we may so lead our lives as to be worthy in Thy sight.

Now. as we go to our separate ways, alone, for Thou, O Lord, goest with us and the love of our brethren continues to be with us and we know that,

Oft in the Crowd, and oft when alone,
When evil allures us and sin seems so strong,
There come to the heart the words,
“No—do not the Wrong”.

Omnes: S.M.I.B.

31. To honour the Charity Box.
32. To announce Donations.
33. Felicitations by the visiting Brethren.
34. To transact such other business that may be placed before the Lodge.
35. Triple Enquiry
 - 1st : MW The Grand Master and his Deputation will retire after the First Enquiry.
 - 2nd : RW The Regional Grand Master and his Deputation will retire after the Second Enquiry.
 - 3rd : Visiting Brethren to convey their Greetings.
36. To close the Lodge.

Closing Hymn

Now the evening shadows closing,
Worn from toil to peaceful rest,
Mystic arts and Rites reposing,
Sacred in each faithful breast.

God of light! Whose love unceasing,
Doth to all Thy works extend,
Crown our order with Thy blessing,
Build, sustain us to the end.

Humbly now we bow before Thee,
Grateful for Thine aid Divine,
Everlasting power and glory,
Mighty Architect be Thine.

S.M.I.B.

National Anthem

CENTENARY CELEBRATIONS OF A HOLY ROYAL ARCH CHAPTER

CEREMONIAL

1. To open the Chapter.
2. To read the Summons convening the Convocation.
3. To read and confirm the Minutes of the last regular convocation held on_____.
4. To read and adopt the Minutes of the Chapter Committee *(held if any)*.
5. To receive ME The Grand Superintendent, ME Comp. _____and the members of his Deputation.
6. To receive ME The First Grand Prin., M.E. Comp., _____ and the members of his Deputation.
7. Welcome address by the M.E.Z. and to handover the charge of the Chapter to ME The First Grand Prin.

Welcome address by M.E.Z.

MEZ: I now humbly invite and request M. Ex. The I.G. Prin., ME Comp. _____, our Chief guest to take the chair to conduct the Centenary Celebrations and address the Companions of the Chapter and the guests present here.

G.D.o f C.: Upstanding, Companions. *(All stand while First G. Prin. takes the chair)*

8. ME The First G. Prin. to take the Chair and appoint his Other Principals.

ME The First G. Prin. : E Comp. II & III G. Prins. and E Comp. G. Scribe E you will take your respective places.

(The G.D. of C. and the Dy. G.D.of C. escort the G. Principals and the Grand Scribe E to their respective seats.)

9. ME The First G. Prin. to address the Chapter and call upon the III G. Prin. to offer a Prayer.

Address by M.E. the First G. Prin.

ME The First G. Prin.: Comp. III G. Prin., I call upon you to invoke the Blessings of the T & L G M H.

G.D. of C.: Companions will stand to order with the sign of R.

Prayer

III G. Prin.: O Thou Almighty T & L G M H, Thou Lord of Creation, Giver of Light and Life, in our hour of joy and sorrow, in our days of bliss and woe, we are taught to turn to you not only because it is our Masonic duty but because man hath need of Thee and his heart hungereth for Thee, for Thou art his daily sustenance, for Thou hast pointed out the true path to him, for Thou hast cast upon him the mantle of responsibilities and hast endowed him with the wisdom and ability to fulfill those responsibilities, for Thou hast given him the opportunity of creating greater fellowship through a richer and more meaningful Brotherhood.

Thou hast given us this day the opportunity to receive Thy blessings and we would be remiss as men and we would

fail as Companions of this order if we did not turn to Thee for these blessings.

We, who have for our teachings the greatest teachings of all, find that they are worth nothing if we do not have good and responsible men to live these teachings and to spread them and to share them in all the things that we think and say and do.

Therefore, on this occasion of the Centenary Celebrations of our Chapter we humbly beseech Thy blessings upon our endeavours to make this Order of ours the greatest and most significant Order that is on the face of this earth. Guide us then, we ask in Thy Most Holy and Glorious Name.

Omnes: S.M.I.B.

G.D. of C.: Companions, be seated.

10. ME The First G. Prin. to ask the Grand Scribe E to read the Centenary Warrant.

ME The First G. Prin.: Comp. Grand Scribe E, you will read the Centenary Warrant.

(Grand Scribe E reads the Warrant.)

11. To recite Scriptural extracts from the Volumes of the Sacred law.

ME The First G. Prin.: E Comp.will read the passage from Shrimad Bhagavad Gita.

Shrimad Bhagavad Gita .. Chapter IX

Verses 16 to 19

अहं क्रतुरहं यज्ञः स्वधाहमहमौषधम् ।
णन्त्रो हामहमेवाज्यमहमग्निरहं हुतम् ॥ १ ६ ॥

Verse 16: I am the Kratu, I, the Yajna, I, the Svadha, I, the Aushadham, I, the mantra, I, the Ajyam, I, the fire, and I, the oblation.

पिताहमस्य जगतो माता धाता पितामहः
वेद्यं पवित्रमोकार ऋक् साम यजुरेव च ॥ १ ७ ॥

Verse 17: I am the Father of this World, the Mother, the Sustainer, the Grand-father, the Purifier, the (one) thing to be known, (the syllable) Om, and also the Rik, Sama and Yajus.

गतिर्भर्ता प्रभुः साक्षी निवासः शरणं सहृत् ।
प्रभवः प्रलयः स्थानं निधनं बीजमव्ययम् ॥ १ ८ ॥

Verse 18: The Goal, the Supporter, the Lord, the Witness, the Abode, the Refuge, the Friend, the Origin, the Dissolution, the Substratum, the Store-house, the Seed immutable.

तपाम्यहमहं वर्षं निगृह्णाम्पुत्सृजामि च ।
अमृतं चैव मृत्युश्च सदसच्चाहमर्जुन ॥ १ ९ ॥

Verse 19: As the Sun, I give heat: I withhold and send forth rain; I am immortality and also death; being and non-being am I, O Arjuna !

ME The First G. Prin.: E Comp.will read the passage from the Holy Koran.



بِسْمِ اللَّهِ الرَّحْمَنِ الرَّحِيمِ

أَحْمَدُ لِلَّهِ رَبِّ الْعَالَمِينَ ۝

الرَّحْمَنِ الرَّحِيمِ ۝

مَلِكِ يَوْمِ الدِّينِ ۝

إِيَّاكَ نَعْبُدُ وَإِيَّاكَ نَسْتَعِينُ ۝

إِهْدِنَا الصِّرَاطَ الْمُسْتَقِيمَ ۝

صِرَاطَ الَّذِينَ أَنْعَمْتَ عَلَيْهِمْ ۝ غَيْرِ

الْمَغْضُوبِ عَلَيْهِمْ وَلَا الضَّالِّينَ ۝

Praise be to God, the Cherisher and Sustainer of Worlds; Most Gracious, Most Merciful; Master of the Day of Judgement; Thee do we worship and Thine aid we seek. Show us the Right Path— The Path of those on whom Thou has bestowed Thy grace, Not the path of those who have incurred Thy displeasure nor who have gone astray.

ME The First G. Prin.: E Comp.will read the passage from Zend Avesta.

દાદર હોરમઝદ જરથોસ્ત કહે છે :-

હું છું સરજનહાર બચાવનાર રક્ષણહાર
પોષનાર જાણનાર વૃદ્ધી અને તંદુરસ્તી
બક્ષનાર આશ્રવ અહુર મઝદા અશો
ખોરૈહ પુર દુર નેગહબાન સર્વ વ્યાપક
હું છું કીર્તીવાન પુર્ણરક્ષણહાર તારણહાર
બચાવનાર સર્વ વ્યાપી હું જ છું.

Then spoke Ahura-Mazda, "I am Existence itself, the one and only Reality. I am the Saviour, the Creator and the Guardian of the Universe, the Creator of all life, the Omniscient, the

Righteous, the Soul within everybody, the All-seeing and the Far-seeing. I am the One who looks after everybody, I am the Universal Donor and the Protector who protects everybody. I am the All-Knowing I am the one who looks after the well-being of all I am the One who never deceives and is undeceived. I am the perfect Architect and the Architect of the Universe, the Light Eternal.

ME The First G. Prin.: E Comp.will read the passage from the Holy Bible.

The LORD is my shepherd; I shall not want. He maketh me to lie down in green pastures; he leadeth me beside the still waters. He restoreth my soul; he leadeth me in the Paths of righteousness for His name's sake. Yea, though I walk through the valley of the shadow of death; I will fear no evil; for Thou art with me; Thy rod and thy staff, they conform me. Thou preparest a table before me in the presence of mine enemies; Thou anointest my head with oil; my cup runneth over. Surely goodness and mercy shall follow me all the days of my life; and I will dwell in the house of the LORD forever.

ME The First G. Prin.: E Comp. will read passage from the Holy Granth Saheb.

ਸੋਰਠਿ ਮਹਲਾ ੫ ॥

ਸੋਈ ਕਰਾਇ ਜੋ ਤੁਧੁ ਭਾਵੈ ॥ ਮੋਹਿ ਸਿਆਣਪ ਕਛੁ ਨ ਆਵੈ ॥
ਹਮ ਬਾਰਿਕ ਤਉ ਸਰਣਾਈ ॥ ਪ੍ਰਭਿ ਆਪੇ ਪੈਜ ਰਖਾਈ ॥ ੧ ॥
ਮੇਰਾ ਮਾਤ ਪਿਤਾ ਹਰਿ ਰਾਇਆ ॥
ਕਰਿ ਕਿਰਪਾ ਪ੍ਰਤਿਪਾਲਣ ਲਾਗਾ ਕਰੀ ਤੇਰਾ ਕਰਾਇਆ ॥ ਰਹਾਉ ॥
ਜੀਅ ਜੰਤ ਤੇਰੇ ਧਾਰੇ ॥ ਪ੍ਰਭ ਡੋਰੀ ਹਾਥਿ ਤੁਮਾਰੇ ॥
ਜਿ ਕਰਾਵੈ ਸੋ ਕਰਣਾ ॥ ਨਾਨਕ ਦਾਸ ਤੇਰੀ ਸਰਣਾ ॥੨॥੨॥੨੧॥

O, Merciful Lord, I do Thy will,

My intelligence and my desires are of no use;

I am Thy son and am always at Thy mercy.

It is Thy goodwill and Thou can dispose of me as Thou likest.

We are Thy children and Thou art our Mother and Father.

Oh my Master, Thou art our Creator and Protector.

I feed on the milk of Thy Name and I do whatever is thy will.

Thou art the Creator of the world and The reins are in Thy hands

Thou art my Guide, my Teacher and my Master,

Whatever is Thy will, I do accordingly.

12. To take the Oath of rededication.

ME The First G. Prin.: Comp. G.D.of C., you will now place the M.E.Z of the Chapter in front of the Altar with the II Prin. on his right and the III Prin. on his left, the I.P.Z. behind the M.E.Z. and the Past Z's and the Companions of the Chapter behind the I.P.Z. in rows of 4 each. I will now request the M.E.Z to take the Obligation of rededication.

G.D.of C.: Companions, stand to order with the sign of R whilst the M.E.Z. kneels before the Altar.

M.E.Z : We, the three Principals, Officers and Companions of Chapter _____ No. _____ in the register of the Supreme Grand Chapter of India, in the presence of the T A L G M H and of this Worthy and Worshipful Holy Royal Arch Chapter, do solemnly and sincerely promise that we shall sustain, uphold and transfer, pure and unsullied, the traditions of the order into which we have entered. By this solemn act of rededication we pledge ourselves to strive to acquire wisdom and understanding and to practice the truly masonic virtues of Brotherly Love, Relief and

Truth. So help us Thou T. A. L.G.M.H. and keep us steadfast in this our solemn obligation of rededication.

Omnes : S.M.I.B.

M.E.Z. rises but remains standing with the other Companions, with Sn. of R.

ME The First G. Prin.: Comp. III G. Prin.

Prayer

III G. Prin. (From his seat): Companions let us now invoke the threefold blessings of the T. A. L.G.M.H., in the South, in the West and in the East and pray that His favour vouchsafed to this Chapter, these 100 years may continue and increase to our joy and His Glory.

(from the South in front of the Scribe N's pedestal)

May the T. A. L.G.M.H. who, through the years has so liberally provided for the spiritual and temporal needs of our Companions in this place, continue to pour forth His bounty and make this Chapter rich in Brotherly Love, Benevolence and Charity to the Honour and Glory of His Most Holy Name.

(from the West in front of the Sojourners' seat)

May the All Merciful God who through all these years has given our Companions strength and gladness in their quest

for wisdom and truth, increase in us and our successors every grace and virtue that can adorn and beautify the human mind to the Honour and Glory of His Most Holy Name.

(from the East and on the left of the M.E.Z's Chair)

May the Most Holy and Blessed favour fill our hearts with joy and peace and in knowledge and in service. May He pour forth the oil of harmony and loving kindness upon every enterprise and undertaking and bring us all at length to the Temple of Perfection, to that House, not made with hands, eternal in the Heaven.

Omnes : S.M.I.B.

(Principals and Companions resume their seats.)

13. First G. Principal : Address of congratulations and relinquishment of the charge of the Chapter.

M.E. First G. Prin. will address the Chapter and will hand over charge of the Chapter to the M.E.Z.

(The Grand D of C and the Dy G. D. of C to see to the needful being done accordingly. All Companions stand when ME The I G. Prin. stands).

14. M.E.Z. to resume the Chair along with his other Principals.

M.E.Z. resumes charge of the Chapter.

G.D. of C - M.E., may I have your permission to relieve the other Grand Officers.

M.E.Z. : Yes, you may. (*done*)

M.E.Z. gives Address of thanks to the M.E. First G. Prin. for conducting the ceremony.

15. To call the Roll of and to applaud the Past Z's of and in the Chapter.

M.E.Z.: Companions, I would be failing in my duty were I not to assure, as I do, all my Past Z's, that we shall keep this our Chapter, pure and unsullied, from generation to generation and in so doing we should honour each one of them present here individually. I would request each of them to please rise and acknowledge our humble offering as our Scribe 'E' reads their names and the year when they were the Ruling Zs. And you, my Companions, will please give an applause as each of them rises from his seat.

Comp. Scribe E, you will please read out the names of Past Z's of and in the Chapter present. (*Each P.Z. will rise as his name is called, give the sign of reverence and resume his seat. Companions will give an applause as each P.Z. rises from his seat.*)

16. To ballot for election the following Honorary Members:
(*if any*)
17. Release of the Centenary Jewel by M.E. First G. Prin.

M.E.Z. requests M.E. First G. Prin. to release the Centenary Jewel.

M.E. The First G. Prin. releases the Centenary Jewel.

18. M.E.Z. to present the Centenary Jewels.

Presentation of Centenary Jewel to M.E. First G .Prin. and M.E. G. Supdt. and M.E. the I.G.Prin. for the Central Masonic Library & Museum.

19. Distribution of the Centenary Jewel amongst the Companions.

M.E.Z.: I request M.E. The I G. Prin. to distribute the Centenary Jewel to the Companions concerned.

20. Release of Centenary Souvenir.

M.E.Z.: I now request M.E. The First G. Prin. to release the Centenary Souvenir.

M.E. The I G. Prin. will release the Centenary Souvenir.

21. M.E.Z. to present Souvenir copies to M.E. The First G. Prin., M.E. The G. Suptd. and the Grand and Regional Grand Officers.

Presentation of Souvenir to M.E. The First G. Prin., M.E. The G. Suptd. and their officers.

22. Address of Thanks by the M.E.Z. to First G. Prin., M.E. The G Supdt.

M.E.Z. gives thanks.

M.E. The G. Supdt. will give thanks and say a few words.

23. Thanksgiving Prayer by Ill. Prin. (J).

D of C : Companions, to order, with the sign of R.

Thanksgiving Prayer

Ill. Prin. (J) of the Chapter:

Almighty God, our Father, as we come to the close of these Celebrations, as ever our thoughts turn to Thee. Though we have in our hearts a sense of accomplishment, we seek Thy guidance and direction for there is much yet to be done. We are grateful to Thee for all that has transpired here and we pray for strength to accomplish the task that Thou hast set before us. We have received good counsel from men who have in their hearts the Love of God and a concern for the Order. Grant us wisdom to heed their counsel and ability to emulate their mode of living to set a good example of Royal Arch Masonry in our communities in every area of our lives and not just in our Temples. Strengthen our hearts for an abiding belief in Thee O God, and grant that we may so lead our lives as to be worthy in Thy sight.

Now, as we go to our separate ways alone, for Thou, O Lord, goest with us and the Love of our Companions continues to be with us and we know that,

Oft in the Crowd and oft when alone,
When evil allures us and sin seems so strong
There comes to the heart the words,
“No - do not the wrong.”

Omnes: S.M.I.B.

24. To honour the Charity Box.
25. To announce donations.
26. Felicitations by the visiting Companions.
27. To transact such other business that may be placed before the Chapter.
28. The customary risings
29. M.E. The First G. Prin. and his Deputation will retire at first rising.
30. M.E. The G. Supdt. and his deputation will retire at second rising.
31. To close the Chapter.

NATIONAL ANTHEM

CENTENARY CELEBRATIONS OF A MARK LODGE CEREMONIAL

1. To open the Lodge.
2. To read the Summons convening the Meeting.
3. To read and confirm the Minutes of the last Regular meeting held on_____.
4. To read and adopt the Minutes of the Lodge Committee *(held if any)*.
5. To receive, welcome and greet R.W. The Regional Grand Mark Master, R. W. Bro. _____ and the Members of his Deputation.
6. To receive, welcome and greet M.W. The Grand Master, M.W. Bro. _____, and the Members of his Deputation.
7. Welcome address by the Worshipful Master and to hand-over the charge of the Lodge to M.W. The Grand Master.

Welcome address by W.M.

W.M.: I now humbly invite and request M.W. Bro. _____, MW the G.M. of the Grand Lodge of Mark Master Masons of India, our Chief guest to take the chair to conduct the Centenary Celebrations and address the Brethren of the Lodge and the guests present here.

8. M.W. The Grand Master to take the Chair and appoint his Wardens.

(MW The G.M. takes the Chair – all brethren stand)

M.W. the G.M.: Brother Grand Wardens you will take your respective places. Bro. _____, you will officiate as the Chaplain, and Bro. _____, you will act as Secretary.

(The Grand D of C and his Deputy escort the Grand Officers. to their respective seats.)

9. M.W. the Grand Master to address the Lodge and call upon G. Chaplain to offer a Prayer.

Address by M.W. the Grand Master

MW The Grand Master: Bro. G. Chaplain, I call upon you to invoke the Blessings of the G.O.O.T.U.

G.D. of C.: Brethren will stand to order with the sign of R.

Prayer

G. Chaplain: O Thou G.O.O.T.U., Thou Lord of Creation, Giver of Light and Life, in our hour of joy and sorrow, in our days of bliss and woe, we are taught to turn to you not only because it is our Masonic duty but because man hath need of Thee and his heart hungereth for Thee, for Thou art his daily sustenance, for Thou hast pointed out the true path to him, for Thou hast cast upon him the mantle of responsibilities and hast endowed him with the wisdom and ability to fulfill those responsibilities, for Thou hast given him the opportunity of creating greater fellowship through a richer and more meaningful Brotherhood.

Thou hast given us this day the opportunity to receive Thy blessings and we would be remiss as men and we would fail as Masonic Brethren if we did not turn to Thee for these blessings.

We, who have for our teachings, the greatest teachings of all, find that they are worth nothing if we do not have good and responsible men to live these teachings and to spread them and to share them in all the things that we think and say and do.

Therefore, on this occasion of the Centenary Celebrations of our Lodge we humbly beseech Thy blessings upon our endeavours to make this Fraternity of ours the greatest and most significant Fraternity that is on the face of this earth. Guide us then, we ask in Thy Most Holy and Glorious Name.

Omnes: S.M.I.B

G. D. of C.: Brethren, be seated.

10. M.W. The Grand Master to ask the Grand Secretary to read the Centenary Warrant.

M.W. The G.M.: Bro. Grand Secretary, you will read the Centenary Warrant.

(Grand Secretary reads the Warrant.)

11. To recite Scriptural extracts from the Volumes of the Sacred law.

MW G.M.: W.Bro.....will read the passage from Shrimad Bhagavad Gita.

Shrimad Bhagavad Gita .. Chapter IX
Verses 16 to 19

अहं क्रतुरहं यज्ञः स्वधाहमहमौषधम् ।
गन्त्रो हमहमेवाज्यमहमग्निरहं हुतम् ॥ १ ६ ॥

Verse 16: I am the Kratu, I, the Yajna, I, the Svadha, I, the Aushadham, I, the mantra, I, the Ajyam, I, the fire, and I, the oblation.

पिताहमस्य जगतो माता धाता पितामहः
वेद्यं पवित्रमोँकार ऋक् साम यजुरेव च ॥ १ ७ ॥

Verse 17: I am the Father of this World, the Mother, the Sustainer, the Grand-father, the Purifier, the (one) thing to be known, (the syllable) Om, and also the Rik, Sama and Yajus.

गतिर्भर्ता प्रभुः साक्षी निवासः शरणं सहत् ।
प्रभवः प्रलयः स्थानं निधनं बीजमव्ययम् ॥ १ ८ ॥

Verse 18: The Goal, the Supporter, the Lord, the Witness, the Abode, the Refuge, the Friend, the Origin, the Dissolution, the Substratum, the Store-house, the Seed immutable.

तपाम्यहमहं वर्षं निगृह्णाम्पुत्सृजामि च ।
अमृतं चैव मृत्युश्च सदसच्चाहमर्जुन ॥ १ ९ ॥

Verse 19: As the Sun, I give heat: I withhold and send forth rain; I am immortality and also death; being and non-being am I, O Arjuna !

MW G.M.: W. Bro.....will read the passage from the Holy Koran.



١- بِسْمِ اللَّهِ الرَّحْمَنِ الرَّحِيمِ ۞

٢- الْحَمْدُ لِلَّهِ رَبِّ الْعَالَمِينَ ۞

٣- الرَّحْمَنِ الرَّحِيمِ ۞

٤- مَلِكِ يَوْمِ الدِّينِ ۞

٥- إِيَّاكَ نَعْبُدُ وَإِيَّاكَ نَسْتَعِينُ ۞

٦- اهْدِنَا الصِّرَاطَ الْمُسْتَقِيمَ ۞

٧- صِرَاطَ الَّذِينَ أَنْعَمْتَ عَلَيْهِمْ غَيْرِ

٨- الْمَغْضُوبِ عَلَيْهِمْ وَلَا الضَّالِّينَ ۞

Praise be to God, the Cherisher and Sustainer of Worlds; Most Gracious, Most Merciful; Master of the Day of Judgement; Thee do we worship and Thine aid we seek. Show us the Right Path— The Path of those on whom Thou has bestowed Thy grace, Not the path of those who have incurred Thy displeasure nor who have gone astray.

MW G.M.: W.Bro.....will read the passage from Zend Avesta.

દાદર હોરમઝદ જરથોસ્ત કહે છે :-

હું છું સરજનહાર બચાવનાર રક્ષણહાર
પોષનાર જાણનાર વૃદ્ધી અને તંદુરસ્તી
બક્ષનાર આશ્રવ અહુર મઝદા અશો
ખોરેહ પુર દુર નેગહબાન સર્વ વ્યાપક
હું છું કીર્તીવાન પુર્ણરક્ષણહાર તારણહાર
બચાવનાર સર્વ વ્યાપી હું જ છું.

Then spoke Ahura-Mazda, "I am Existence itself, the one and only Reality. I am the Saviour, the Creator and the Guardian of the Universe, the Creator of all life, the Omniscient, the Righteous,

the Soul within everybody, the All-seeing and the Far-seeing. I am the One who looks after everybody, I am the Universal Donor and the Protector who protects everybody. I am the All-Knowing: I am the one who looks after the well-being of all.....I am the One who never deceives and is undeceived. I am the perfect Architect and the Architect of the Universe, the Light Eternal.

MW G.M. : W.Bro.....will read the passage from the Holy Bible.

The LORD is my shepherd; I shall not want.

He maketh me to lie down in green pastures; he leadeth me beside the still waters.

He restoreth my soul; he leadeth me in the Paths of righteousness for His name's sake.

Yea, though I walk through the valley of the shadow of death; I will fear no evil; for Thou art with me; Thy rod and thy staff, they conform me.

Thou preparest a table before me in the presence of mine enemies; Thou anointest my head with oil; my cup runneth over.

Surely goodness and mercy shall follow me all the days of my life; and I will dwell in the house of the LORD for ever.

MW The G.M.: W. Bro..... will read passage from the Holy Granth Saheb.

ਸੋਰਠਿ ਮਹਲਾ ੫ ॥

ਸੋਈ ਕਰਾਇ ਜੋ ਤੁਧੁ ਭਾਵੈ ॥ ਮੋਹਿ ਸਿਆਣਪ ਕਛੂ ਨ ਆਵੈ ॥

ਹਮ ਬਾਰਿਕ ਤਉ ਸਰਣਾਈ ॥ ਪ੍ਰਭਿ ਆਪੇ ਪੈਜ ਰਖਾਈ ॥ ੧ ॥

ਮੇਰਾ ਮਾਤ ਪਿਤਾ ਹਰਿ ਰਾਇਆ ॥

ਕਰਿ ਕਿਰਪਾ ਪ੍ਰਤਿਪਾਲਣ ਲਾਗਾ ਕਰੀ ਤੇਰਾ ਕਰਾਇਆ ॥ ਰਹਾਉ ॥

ਜੀਅ ਜੰਤ ਤੇਰੇ ਧਾਰੇ ॥ ਪ੍ਰਭ ਡੋਰੀ ਹਾਥਿ ਤੁਮਾਰੇ ॥

ਜਿ ਕਰਾਵੈ ਸੋ ਕਰਣਾ ॥ ਨਾਨਕ ਦਾਸ ਤੇਰੀ ਸਰਣਾ ॥੨॥੨॥੨੧॥

O, Merciful Lord, I do Thy will,

My intelligence and my desires are of no use;

I am Thy son and am always at Thy mercy.

It is Thy goodwill and Thou can dispose of me as Thou likest.

We are Thy children and Thou art our Mother and Father.

Oh my Master, Thou art our Creator and Protector.

I feed on the milk of Thy Name and I do whatever is thy will.

Thou art the Creator of the world and The reins are in Thy hands

Thou art my Guide, my Teacher and my Master,
Whatever is Thy will, I do accordingly.

12. To take the Oath of rededication.

M.W. The G.M. : Bro. G. D of C you will now place the W.Master of the Lodge in front of the Altar and S.W. of the Lodge on his right and the J.W. on his left, the I.P.M. behind the W.M. and the Past Masters and the Brethren of the Lodge behind the I.P.M. in rows of 4 each.

I will now request the W.Master to take the Obligation of rededication.

G.D of C.: Brethren, stand to order with the sign of R whilst the W. Master kneels before the Altar.

W. Master: We, the Master, Officers and Members of Mark Lodge _____ No. _____ in the register of the Grand Lodge of Mark Master Masons of India, in the presence of the G.O.O.T.U. and of this Worthy and Worshipful Mark Lodge, do solemnly and sincerely promise that we shall sustain, uphold and transfer, pure and unsullied, the traditions of the order into which we have entered. By this solemn act of rededication we pledge ourselves to strive to acquire wisdom and understanding and to practice the truly Masonic

Virtues of Brotherly Love, Relief and Truth. So help us, Thou G.O.O.T.U. and keep us, steadfast in this our solemn obligation of rededication.

Omnes: S.M.I.B.

W.M. rises but remains standing with the other brethren with Sn. of R.

Prayer

Bro. G. Chaplain (*From his seat*): Brethren let us now invoke the threefold blessings of the Lord God of Heaven and Earth, in the South, in the West and in the East and pray that His favour vouchsafed this Mark Lodge, these 100 years may continue and increase to our joy and His Glory.

(From the South in front of the J.W.'s pedestal): May the G.O.O.T.U who, through the years has so liberally provided for spiritual and temporal needs of our Brethren in this place, continue to pour forth His Bounty and make this Mark Lodge rich in Brotherly Love, Benevolence and Charity to the Honour and Glory of His Most Holy Name.

(From the West in front of the S.W.'s pedestal):

May the All Merciful God, who through all these years has given our Brethren strength and gladness in their quest

for wisdom and truth, increase in us and our successors every grace and virtue that can adorn and beautify the human mind to the Honour and Glory of His Most Holy Name.

(From the East and to the left of the W Master): May the Most Holy and Blessed favour fill our hearts with joy and peace and in knowledge and in service. May He pour forth the oil of harmony and loving kindness upon every enterprise and undertaking and bring us all at length to the Temple of Perfection; to that House, not made with hands, eternal in the Heavens.

Omnes: S.M.I.B.

Bro. G. D. of C.: Brethren, resume their seats.

13. Address of congratulations by M.W. the G.M. and relinquishment of the charge of the Lodge.

M.W. The Grand Master will address the Lodge and hand over charge of the Lodge to the W.M.

(The Grand D of C and the Lodge D of C to see to the needful being done accordingly).

14. W.M. to resume the Chair along with his Officers.

WM resumes charge of the Lodge.

G.D. of C: W.M., may I have your permission to relieve the Grand Wardens and other Grand Officers.

W.M.: Yes, you may. *(done.)*

W.M.: Address of thanks to M.W. The Grand Master for performing the ceremony.

15. To call the Roll of the Past masters of and in the Lodge and to applaud the Past Masters of and in the Lodge.

W. Master: Brethren, I would be failing in my duty were I not to assure, as I do, all my Past Masters, that we shall keep this our Mark Lodge, pure and unsullied, from generation to generation and in so doing we should honour each one of them present here individually. I would request each of them to please rise and acknowledge our humble offering as our W. Bro. Secretary reads their names and the year when they were the Ruling Masters. And you, my Brethren, will please give an applause as each of them rises from his seat.

W. Bro. Secretary you will please read out the names of Past Masters of and in the Lodge present.

(Each P.M. will rise, give the sign and resume his seat Brethren will give an applause as each P.M. rises from his seat.)

16. To ballot for election the following Honorary Members *(if any)*

17. Release of the Centenary Jewel by M.W. The Grand Master.

W.M. requests M.W. The Grand Master to release the Centenary Jewel.

M.W. The Grand Master releases the Centenary Jewel.

18. W.M. to present the Centenary Jewels.

Presentation of Centenary Jewel to M.W. The Grand Master, R.W. The R.G.M.M. and M.W. The Grand Master for the Central Masonic Library & Museum.

19. Distribution of the Centenary Jewel amongst the Brethren.

W.M.: I request M.W. the Grand Master to distribute the Centenary Jewel to the Brethren concerned. *(Done)*

20. Release of Centenary Souvenir.

W.M.: I now request M.W. the Grand Master to release the Centenary Souvenir.

M.W. The Grand Master releases the Centenary Souvenir.

21. W.M. to present Souvenir copies to M.W. The Grand Master, and R.W. The Regional Grand Mark Master and the Grand Lodge and Regional Grand Mark Lodge Officers.

Presentation of Souvenir to M.W. the Grand Master, R.W. The R.G.M.M. and their officers.

22. Address of Thanks by the W.M. to M.W. The Grand Master and R.W. The Regional Grand Mark Master.

W.M. gives address of thanks.

RW The R.G.M.M. will give thanks and say a few words.

23. Lodge Chaplain to offer a thanks giving Prayer.

Thanksgiving Prayer

Bro. Chaplain of the Lodge (*Brethren to stand to order with the sign of R.*):

Almighty God, our Father, as we come to the close of these Celebrations, as ever our thoughts turn to Thee. Though we have in our hearts a sense of accomplishment, we seek Thy guidance and direction for there is much yet to be done. We are grateful to Thee for all that has transpired here and we pray for strength to accomplish the task that Thou hast set before us. We have received good counsel from men who have in their hearts the Love of God and a concern for the Fraternity. Grant us wisdom to heed their counsel and ability to emulate their mode of living to set a good example of Masonry in our communities in every area of our lives and not just in our Lodge Temples. Strengthen our hearts for an abiding belief in Thee O God, and grant that we so lead our lives as to be worthy in Thy sight.

Now, as we go to our separate ways alone, for Thou, O Lord, goest with us and the Love of our brethren continues to be with us and we know that,

Oft in the Crowd and oft when alone,
When evil allures us and sin seems so strong
There comes to the heart the words,
“No - do not the wrong.”

Omnes : S.M.I.B.

24. To honour the Charity Box.
25. To announce Donations.
26. Felicitations by the visiting Brethren.
27. To transact such other business that may be placed before the Lodge.
28. Triple Enquiry.
 - 1st : M.W. The Grand Master and his Deputation will retire after the First Enquiry.
 - 2nd : R.W. The Regional Grand Master and his deputation will retire after the Second Enquiry.
 - 3rd : Visiting brethren to convey their Greetings
29. To close the Lodge.

**CENTENARY CELEBRATIONS OF A ROYAL ARK
MARINERS LODGE CEREMONIAL**

1. To open the RAM Lodge.
2. To read the summons convening the Meeting.
3. To read and confirm the Minutes of the Regular Meeting held on
4. To read and adopt the Minutes of the RAM Lodge Committee (if any)
5. To receive, welcome and greet R.W. the Regional Grand Mark Master, R.W. Bro.....and the Members of his Deputation.
6. To receive, welcome and greet M.W The Grand Master, M.W. Bro. and the Members of his Deputation.
7. Welcome address by the W.C.N and to handover the charge of the Lodge to M.W. The Grand Master.

Welcome address by W.C.N.

W.C.N.: I now humbly invite and request M.W. Bro., MW The G.M. of The Grand Lodge of Mark Master Masons of India, our chief guest to take the chair to conduct the Centenary celebrations and address the brethren of the Lodge and the guests present here.

8. M.W. The Grand Master takes the Chair (*Brethren to be upstanding*) and appoints his Wardens.

M.W. the G.M. : Brother Grand Wardens you will take your respective places. Brother....., you will officiate as the Chaplain, and Bro....., you will act as Scribe.

(The G. D. of C. and the Dy. G. D. of C. escort the G.Ws. to their respective seats.)

9. M.W. the Grand Master to address the Lodge and call upon G. Chaplain to offer a Prayer.

M.W. The G.M.: Bro. G Chaplain, I call upon you to invoke the Blessings of the S.C.O.T.U.

G.D. of C: Brethren will stand to order with the sign of F.

Prayer

Grand Chaplain: O Thou Almighty S.C.O.T.U., Thou Lord of Creation, Giver of Light and Life, in our hour of joy and sorrow, in our days of bliss and woe, we are taught to turn to you not only because it is our Masonic Duty but because man hath need of Thee and his heart hungereth for Thee, for Thou art his daily sustenance, for Thou hast pointed out the true path to him, for Thou hast cast upon him the mantle of responsibilities and hast endowed him with the wisdom and ability to fulfill those responsibilities, for Thou hast given him the opportunity of creating greater fellowship through a richer and more meaningful brotherhood.

Thou hast given us this day the opportunity to receive Thy blessings and we would be remiss as men and we would fail as Masonic Brethren if we did not turn to Thee for these blessings.

We, who have for our teachings the greatest teachings of all, find that they are worth nothing if we do not have good and responsible men to live these teachings and to spread them and to share them in all the things that we think and say and do.

Therefore, on this occasion of the Centenary Celebrations of our RAM Lodge we humbly beseech Thy Blessings upon our endeavours to make this Fraternity of ours the greatest and most significant Fraternity that is on the face of this earth. Guide us, then we ask in Thy Most Holy and Glorious Name.

Omnes: S.M.I.B.

G.D. of C: Brethren , be seated.

10. M.W. The Grand Master to ask the Grand Scribe to read the Centenary Warrant.

MW The G.M.: Bro Scribe, you will read the Centenary Warrant. (*Grand Scribe reads the Warrant.*)

11. To take the Oath of rededication.

M.W.G.M.: Bro. G.D. of C. you now place the W.C.N. of the Lodge in front of the Altar and S.W. of the Lodge on his

right and the J.W. on his left, the I.P.C.N. behind the W.C.N. and the Past Commanders and the Brethren of the Lodge behind the I.P.C.N. in rows of 4 each. I will now request the W.C.N. to take the Obligation of rededication.

G.D. of C.: Brethren, stand to order with the sign of F whilst the W.C.N Stands before the Altar and takes obligation of rededication.

W.C.N. : We, the W.C.N., Officers and Members of RAM Lodge..... No....., in the Register of the Grand Lodge of Mark Master Masons of India, in the presence of the S.C.O.T.U. and of this Worthy and Worshipful RAM Lodge, do solemnly and sincerely promise that we shall sustain, uphold and transfer, pure and unsullied, the traditions of the order in to which we have entered. By this solemn act of rededication we pledge ourselves to strive to acquire wisdom and understanding and to practice the truly Masonic Virtues of Brotherly Love, Relief and Truth. So help us Thou S.C.O.T.U. and keep us steadfast in this our solemn obligation of rededication.

Omnes: S.M.I.B.

(W.C.N. remains standing with the other Brethren.)

12.

PRAYER

Chap: *(From his place)*: Brethren let us now invoke the three fold blessings of the S.C.O.T.U. and pray that His favour vouchsafed this Lodge these 100 years may continue and increase to our joy and His Glory.

(From the front of the J.W.'s pedestal): May the S.C.O.T.U. who, through the years has so liberally provided for the spiritual and temporal needs of our Brethren in this place, continue to pour forth His Bounty and make this RAM Lodge rich in Brotherly Love, Benevolence and Charity to the Honour and Glory of His Most Holy Name.

(From the front of the S.W.'s pedestal): May the All Merciful God who through all these years has given our Brethren strength and gladness in their quest for wisdom and truth, increase in us, and our successors, every grace and virtue that can adorn and beautify the human mind, to the Honour and Glory of His Most Holy Name.

(From the East and to the left of W.C.N.'s pedestal): May the Most Holy and Blessed favour fill our hearts with joy and peace and in knowledge and in service. May He pour forth the oil of harmony and loving kindness upon every enterprise and undertaking and bring us all at length to the Temple of Perfection, to that House, not made with hands, eternal in the Heavens.

Omnes : S.M.I.B.

(W.C.N.. and Brethren resume their seats.)

13. Address of congratulations by M.W. the G.M and relinquishment of the charge of the Lodge.

M.W. The Grand Master addresses the RAM Lodge and thereafter hands over charge of the Lodge to the W.C.N.

(Grand D. of C. and the Lodge D. of C. to see to the needful being done accordingly).

14. W.C.N. to resume the Chair along with his Officers.

W.C.N. resumes charge of the Lodge

G.D. of C.: W.C.N., May I have your permission to relieve the Grand Wardens and other Grand Officers?

W.C.N. : Yes, you may. *(done)*

W.C.N.: Address of thanks to the M.W. The Grand Master for performing the ceremony.

15. To call the Roll of the Past Commanders of and in the Lodge and to applaud them.

W.C.N. :Brethren, I would be failing in my duty were I not to assure, as I do, all my Past Commanders that we shall keep this our Lodge, pure and unsullied from generation to generation and in so doing we should honour each one of them present here individually. I would request each of them to please rise and acknowledge our humble offering as our W. Bro. Scribe reads their names and the year when they were the Ruling Commanders. And you, my Brethren, will please give an applause as each of them rises from his seat.

W.C.N.: Bro. Scribe you will please read out the names of Past Commanders of and in the Lodge present. *(Each P.C. rises, gives the sign and resumes his seat. Brethren will give an applause as each P.C. rises from his seat.)*

16. To ballot for Honorary Members, if any :
17. Release of the Centenary Jewel by M.W. The Grand Master.

W.C.N. requests M.W. the Grand Master to release the Centenary Jewel.

M.W. The Grand Master will release the Centenary Jewel.

18. W.C.N. to present the Centenary Jewels.

Presentation of Centenary Jewel to M.W. The Grand Master, R.W. The R.G.M.M. and M.W. The Grand Master for the Central Masonic Library & Museum

19. Distribution of the Centenary Jewel amongst the Brethren.

W.C.N. requests M.W. the Grand Master to distribute the Centenary Jewel to the Brethren.

20. Release of Centenary Souvenir.

W.C.N. requests M.W. The Grand Master to release the Centenary souvenir.

M.W. The Grand Master will release the Centenary Souvenir.

21. W.C.N. To present Souvenir copies to M.W. The grand Master and R.W. The Regional Grand Mark Master and the Grand and Regional Grand Officers.
22. Address of Thanks by the W.C.N. to M.W. The Grand Master.
23. R.G.M.M. will give thanks and say a few words.
24. Bro. Chaplain to offer a Thanks giving Prayer.

Lodge D. of C: Brethren to stand to order with the sign of R.

Thanksgiving Prayer

Bro. Chaplain: Almighty God, our Father, as we come to the close of these Celebrations, as ever our thoughts turn to Thee. Though we have in our hearts a sense of accomplishment, we seek Thy guidance and direction for there is much yet to be done. We are grateful to Thee for all that has transpired here and we pray for strength to accomplish the task that Thou hast set before us. We have received good counsel from men who have in their hearts the Love of God and a concern for the Fraternity. Grant us wisdom to heed their counsel and ability to emulate their mode of living to set good example of Masonry in our communities and in every area of our lives and not just in our Lodge Temples. Strengthen our hearts for an

abiding belief in Thee O God that we may so lead our lives
as to be worthy in Thy sight.

Now, as we go to our separate ways alone, for Thou, O
Lord, goest with us and the love of our brethren continues
to be with us and we know that,

Oft in the crowd, and oft when alone,
When evil allures us and sin seems so strong,
There comes to the heart the words,
“No – do not the wrong”.

Omnes: S.M.I.B

25. To honour the Charity Box.
26. To announce Donations.
27. Felicitations by the visiting Brethren.
28. To transact such other business that may be placed before
the Lodge.
29. Customary rising.
30. M.W. The Grand Master and his Deputation will retire.
31. R.W. The Regional Grand Mark Master and his Deputation
will retire.
32. To Close the Lodge.

National Anthem

THE CEREMONY OF CONSECRATION OF A CRAFT LODGE

General Instructions:

1. Consecrating team is a Grand Lodge team and shall therefore wear only the Grand Lodge Regalia.
2. The G.D. of C. will form the ingoing procession in accordance with the seniority of protem office and not as per the seniority of individual rank.
3. The Consecrating Officer with the assistance of his team will open a casual Lodge. No separate team shall be formed for opening a casual Lodge. The Consecrating Officer, after occupying the Eastern Chair shall appoint the Protem Officers who will bow to the Consecrating Officer and proceed to their respective seats. The Lodge will be opened by the Consecrating Team in all the Three Degrees and the Ceremony of Consecration shall be done in the Third Degree.
4. In the opening Ceremony the Consecrating Officer is to be addressed as W.M., and not as M.W., the Grand Master or R.W., the R.G.M. etc.
5. The Consecrating Officer, if he so desires, may address the brethren immediately after the Ceremony of consecration, but before he hands over the charge to the Installing Officer.
6. As the Consecrating Officers are relieved of their pro-tem offices', they will be seated on the dais on the right of the W.M., in accordance with their seniority and the Regalia they are wearing.

7. After the installation, the W.M. should request any Past Master to act as I.P.M., but will not invest him.
8. Brethren will remain standing during the four Circuits and Censing of the Lodge right up to the Benediction Prayer.
9. The Treasurer and Tyler should be elected before the Investiture of Officers of the Lodge is taken up.
10. The Bye-Laws of the Lodge should be first adopted in open Lodge before they are presented to the newly installed W.M.
11. The G.D.of C, shall form the outgoing procession in accordance with the Seniority and the Regalia worn by Consecrating Officers.

Requisites

1. All normal properties and furniture of a Lodge.
2. Consecrating vessels and censer (to be procured from respective R.G.Ls.)
3. Consecrating elements - Corn, Wine, Oil and Salt.
4. Incense, Camphor and Match box.
5. One Long Table with Cloth for Lodge Boards and One Small table with Cloth for placing for Consecrating vessels.
6. Four Saucers.
7. Charter or Warrant.

8. Book of Constitutions, Byelaws of the Regional Grand Lodge, draft bye-laws of the Lodge.
9. Seats on the dias at the right of W.M., for Consecrating Officers.
10. Two seats in North-east for the G. D. of C. and his Dy.
11. Seats for the petitioners in South-East. The Master and Wardens designate in front.

CEREMONIAL

- G. D. of C. (*At Lodge door*): Upstanding Brethren to receive the Consecrating Officer, M.W.
 Bro.....accompanied by the Consecrating Officers.

The Consecrating Officers, Juniors leading enter in pairs, open out, halt and turn inwards. The Consecrating Officer (CO.) appoints his Officers, protem. Each in turn bows and proceeds direct to his place unescorted. The Consecrating Officer, after occupying the E chair opens the Lodge in all the Three Degrees. (*Tracing Boards are not opened*). The G. D. of C. then calls upon the brethren to salute the CO.

- CO.: Brethren, we have assembled here for the laudable purpose of consecrating a new Lodge and constituting it into a Lodge of Free and

Accepted Masons so that it may act as a regular Lodge and initiate, pass and raise candidates for freemasonry and perform rites and ceremonies conformably with our Antient Charges and the Constitutions of the Order. We are pleased and happy to have the opportunity to welcome this addition to our family. Before I proceed with the ceremony of consecration, I call upon the Chaplain to give the opening prayer.

G. D. of C.: To order brethren

(All give Sn. Of R.)

Chap.: "O Lord our Heavenly Father, Architect and Ruler of the Universe, who dost from Thy throne behold all dwellers upon earth, direct us in all our doings with Thy most gracious favour and further us with Thy continual help that in all our works begun, continued and ended in Thee, we may glorify Thy Most Holy name".

Omnes: S.M.I.B.

G. D. of C.: Be seated brethren.

(G. D. of C. from the front of S.W.'s chair and with no Sn. addresses the CO)

G. D. of C.: Most Worshipful the C.O., a number of brethren duly instructed in the mysteries of the Craft, who

are now assembled, have requested me to inform you of their gratitude that you, M.W. The Grand Master have been pleased to grant them a Charter or a warrant of Constitution bearing (date)..... corresponding to theSaka Era authorizing them to form and open a Lodge of Free and Accepted Masons, to be known as Lodgebearing No..... on the Register of Grand Lodge of India to meet at.....in the Region of Northern/Eastern/Southern/Western India and are desirous that this Lodge be consecrated and their officers invested and installed according to the ancient usages and established customs of the Order for which purpose they are now assembled and await your pleasure.

(If someone other than MW The G.M. is C.O., then for the words "MW" substitute the words "RW" and for the words "you, M.W. The Grand Master have", substitute "MW the G.M. has")

CO: I will thank the brethren who signed the petition to stand in the body of the Lodge while the Grand Secretary reads the Warrant or Charter.

D of C: The petitioners will stand in the East, the Master Designate in front, with the S.W. Designate on his right and J.W. Designate on his left and the other petitioners formed behind, all facing East.

(The G. D. of C. leads the Master Designate and the Wardens Designate to their positions in the East and then arranges the brethren behind them. He shows the Warrant to the CO. and then hands it over to the Grand Secretary, who reads the Warrant.)

CO.: After due deliberation, and by virtue of the authority vested in me, I, as The Grand Master of the Grand Lodge of India, have granted to the brethren of this new Lodge a Warrant establishing in them all the rights and privileges of our Order, and I now enquire of the Petitioners whether they approve of the officers named in the Warrant to preside over them.

(If someone other than M.W. the Grand Master is the CO. then for the words "and by virtue of the authority vested in me, I, as The Grand Master of the Grand Lodge of India have" substitute the words "M.W. The Grand Master, by virtue of the authority vested in him as the Grand Master of the Grand Lodge of India has")

(The Petitioners, other than the Master and the Wardens Designate signify their approval by the Sn. of F.)

C.O.: Then we will proceed to constitute these brethren into a regular Lodge, and to consecrate it in accordance with ancient usages and customs.

(G. D. of C. leads the Master Designate and the Wardens Designate to their places)

D of C: Petitioners, resume your seats. Be seated brethren.

C.O.: I will now call upon the Chaplain to deliver an Oration on the nature and purpose of our Institution.

THE ORATION *(The Chap, delivers the Oration)*

G. D. of C. : To order brethren. *(All stand with Sn. of R.)*

DEDICATION PRAYER FIRST PART

Chap.: Let us pray. Almighty Father of the Universe, Searcher and Ruler of all worlds, deign from Thy celestial abode, from realms of light and glory, to bless us in all purposes of our assembly. We humbly beseech Thee to give us wisdom in all our doings, strength of mind in all our difficulties, and the

beauty of love and harmony in all our communications. Permit us, O Thou Author of light and life, Great Source of love and happiness, to erect this Lodge and solemnly to consecrate it to the honour and glory of Thy Most Holy Name.

Omnes: S.M.I.B.

G. D. of C.: The brethren will assume an attitude of prayer, turning to the East.

THE INVOCATION

CO.: O Lord God, Supreme thou art in heaven above and on earth beneath, who keepeth thy covenant and showeth mercy unto Thy servants who bow before Thee with all their hearts. Let all the people of the earth know that the Lord, He is God, and that there is none else. Let all the people of the earth know thy name and revere Thee. Let all the people of the earth know that we have built this House and are consecrating it to Thy service. But will Thou, O God, indeed, dwell upon the earth? Behold the heavens and the heaven of heavens cannot contain Thee, how much less this House that we have built?

Yet, we implore Thee to heed to our prayers and supplications, and hearken unto our cry. May Thine eyes be opened towards this House by night as well as by day; and when Thy servants shall pray to Thee from this house, hearken unto their supplication; hear thou in heaven Thy dwelling place, and when Thou hearest, forgive.

Omnes: S.M.I.B.

CO.: Let the Lodge Boards be uncovered.

(The G. D. of C. uncovers the Boards and he or his Deputy takes out the covering cloth.)

G. D. of C.: Brother Wardens, will you please attend on the Consecrating Officer?

(The CO. places himself on the east of the Lodge Boards, facing west with the S.W. on his right and the J.W. on his left. (See Diagram) The G. D. of C. hands the cornucopia filled with corn to the CO., the vessel containing wine to the S.W. and that containing oil to the J.W. bowing to each after doing so.)

First Circuit

CO. *(followed by the S.W. and J.W. in that order, perambulates, saying):* I scatter corn upon this Lodge, the symbol of abundance and plenty. May

the good seed of His word sink into the hearts of men, take root and bring forth fruit a hundred fold.

(All three return to east, and stand facing west as before.)

G. D. of C.: Brethren will sing together

Musical /

Omnes: Glory be to God on High

Second Circuit

(The G. D. of C. takes the cornucopia from the CO. and hands the vessel containing wine to the CO., the vessel containing oil to the S.W. and the cornucopia to the J.W. bowing to each after he has done so.)

CO *(followed by Wardens as before, perambulates, saying)*: I pour wine upon this Lodge, the symbol of joy and gladness. May we ever rejoice in the revelation of truth and may virtue flourish as the wine.

(All three return to the east, and stand facing west as before.)

G. D. of C.: Brethren will sing together

Musical/

Omnes: Glory be to God on High.

Third Circuit

(The G. D. of C. takes the vessel containing wine from the CO. and hands that containing oil to the CO., the vessel containing wine to the J.W. and the cornucopia to the S.W.)

(CO. followed by W.s, as before perambulates saying): I sprinkle oil upon this Lodge, the symbol of peace and harmony. May the peace that passeth all understanding descend from heaven upon you and abide with you for evermore.

(All three return to the east, and stand facing west as before).

G.D. of C. : Brethren will sing together.

Musical/

Omnes: Glory be to God on High.

(The G. D. of C. receives the consecrating vessels from the CO. and the Wardens, and replaces them on the table. He then hands the vessel containing salt, to the CO.)

G. D. of C.: The petitioners will stand round the Lodge Board, the Master and Wardens Designate at the east, all facing outwards.

(The G. D. of C. first leads the Master and Wardens Designate to their places and then arranges the others.- see diagram)

Fourth Circuit

(The C.O. now perambulates alone (*See Diagram*) saying: I strew salt, upon this Lodge the symbol of fidelity, hospitality and everlasting friendship. May these virtues ever continue to distinguish the members of this Lodge until time with them shall be no more.

(The C.O. returns to the east and stands facing west between S.W. and J.W. as before.)

G.D. of C. : *Brethren will sing together.*

Musical/

Omnes: Glory be to God on High.

(The G. D. of C. receives the vessel of salt from the C.O. and replaces it on the table. The C.O. and Wardens resume their places.)

G. D. of C.: To order brethren. (*All give Sn. of R.*)

C.O.: To God and his service I dedicate this Lodge (*Drop Sn. of R.*) and to the memory of the Royal Solomon under whose auspices many of our masonic mysteries are said to have had their origin.

Omnes: S.M.I.B.

(the G. D. of C. leads the W.M. and Wardens designate to their places where they remain standing.)

G. D. of C.: Petitioners, resume your places and remain upstanding.

(The Director or Deputy Director of Ceremonies having previously directed the Tyler to prepare the censer obtains it from him. When the censer is brought into the Lodge, the Chaplain comes and stands in front of the CO. to receive the censer from the G. D. of C.)

Perambulations

(The Chaplain perambulates the Lodge three times in a slow march waving the censer so as to disperse the incense)

First Perambulation (Censing the Lodge)

(The Chap., bows to the CO., turns right and proceeds down the Lodge reciting the following words in slow rhythm.)

“And Aaron shall burn thereon sweet incense”.

(He halts in front of the J.W., faces north and swings the censer twice, slowly walks over to the west, halts in front of the S.W., faces east and swings the censer twice; proceeds in a slow walk along the north, halts opposite and in line with the J.W.'s Chair, faces south and swings the censer twice. He then slowly walks over to the east, halts in front of the CO. and faces him.) (See Diagram)

Second Perambulation (Censing the CO)

(The Chap, bows to the C.O., censes him three times and bows again. He then turns right and proceeds down the Lodge reciting the following)

“Every morning when he dresseth the Lamps, he shall burn incense upon it.”

(He halts in front of S.W., faces him, bows, censes him twice and bows again. He continues round the Lodge until he is in the north, opposite the J.W. He halts, faces the J.W., bows, censes him once across and over the Lodge Boards, and bows again. He then goes back to his position in the east.) (See Diagram).

Third Perambulation (Censing the Master, Wardens Designate and brethren generally)

(The Chap, bows to the C.O., turns right and halts in front of the Master Designate, the S.W. Designate and J.W. Designate in that order on the front row at the East of J.W.'s pedestal. He faces the Master Designate, bows, censes him three times and bows again. He then moves to the front of the S.W. Designate, faces him, bows, censes him twice and bows again. He then moves

to the front of the J.W. Designate, faces him, bows, censures him once and bows again. He then proceeds round the Lodge slowly reciting the following words)

“And when Aaron lighteth the lamps at even, he shall burn incense upon it.

(The Chap, proceeds to the West and halts in front of the S.W.'s pedestal facing east, he half turns to his right towards the south-east, bows to the brethren on that side, censures them once and bows again. He next turns left towards north-east, bows to the brethren on that side, censures them once and bows again. He finally faces the East, bows, censures the brethren in the east once, and then proceeds onwards along the north reciting the following words) (See Diagram)

“A perpetual incense before the Lord throughout your generation.”

(He comes back to his starting position in the east, faces the CO., bows to him, hands the censer to the G.D. of C and returns to his seat. The Dy. G.D. of C takes the censer out of the Temple.)

G. D. of C.: To order brethren.

(All stand with Sn. of R.)

DEDICATION PRAYER SECOND PART

Chap : Grant, O lord, that those who are now about to be invested with the government of this Lodge may

be endued with wisdom to instruct their brethren in all their duties; may brotherly love, relief and truth ever prevail amongst its members and may this bond of union increase and strengthen the several Lodges throughout the world. Bless all our brethren wherever dispersed over the face of earth and water; and grant a speedy relief to all who are oppressed and distressed. We especially and affectionately commend to Thy especial care and attention all the members of the Fraternity, and may they increase in knowledge of Thee and love of each other and finally, may we finish all our work here below with Thy approbation and then leave this earthly abode for Thy Heavenly Temple above, there to enjoy light, bliss and joy now and forevermore.

Omnes: S.M.I.B.

G. D. of C.: The petitioners will stand in the west, the Master and Wardens Designate in front, all facing east.

(The G. D. of C. first leads the Master and Wardens Designate to their places and then arranges the others.)

CO: In the name of the Most High and by virtue of the power and authority vested in me I hereby constitute and form you, my good brethren, into a regular Lodge of Free and Accepted Masons. Henceforth, you are

empowered to act as a regular Lodge and to initiate, pass, and raise candidates for freemasonry and to perform all rites and ceremonies conformably with the Antient Charges and the Constitutions of the Order and I now proclaim this Lodge No.....in the Register of the Grand Lodge of India to have been regularly constituted and dedicated (*Sn. of R. by the C.O. only*) and May the G.A.O.T.U. prosper, direct and counsel you in all your proceedings.

Omnes : S.M.I.B.

G. D. of C.: To order, brethren for the Patriarchal Benediction.

Patriarchal Benediction

Chap.: May the G.A.O.T.U. bless, preserve and keep us evermore. May he lift up the light of His countenance upon us and give us peace, now and for evermore.

Omnes : S.M.I.B.

(The G. D. of C. leads the Master Designate and the Warden Designate to their places and then directs the Founder Members to resume their seats.)

D. of C : Founders, resume your places. Be seated brethren.

End of the Ceremony of Consecration of a Lodge

CONSECRATION OF CRAFT LODGE SEATING ARRANGEMENT

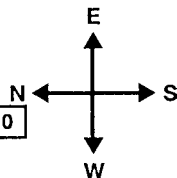
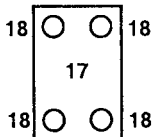
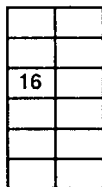
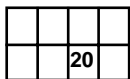

DETAILS OF CONSECRATION OF A LODGE:

1. CONSECRATING OFFICER
2. GRAND SENIOR WARDEN
3. GRAND JUNIOR WARDEN
4. GRAND CHAPLAIN
5. G.D. OF C
6. DY.G.D. OF C
7. GRAND SECRETARY
8. GRAND SWORD BEARER
9. GRAND SENIOR DEACON
10. GRAND JUNIOR DEACON
11. GRAND STANDARD BEARERS
12. GRAND INNER GUARD
13. MASTER DESIGNATE
14. S.W. DESIGNATE
15. J.W. DESIGNATE
16. OTHER PETITIONERS
17. CENTRE TABLE WITH LODGE BOARDS
18. SAUCERS
19. SMALL TABLE WITH WHITE CLOTH FOR PLACING
CONSECRATING VESSELS
20. SEATS FOR CONSECRATING OFFICERS

**CONSECRATION OF CRAFT LODGE
FIRST, SECOND AND THIRD CIRCUITS BY C.O.**

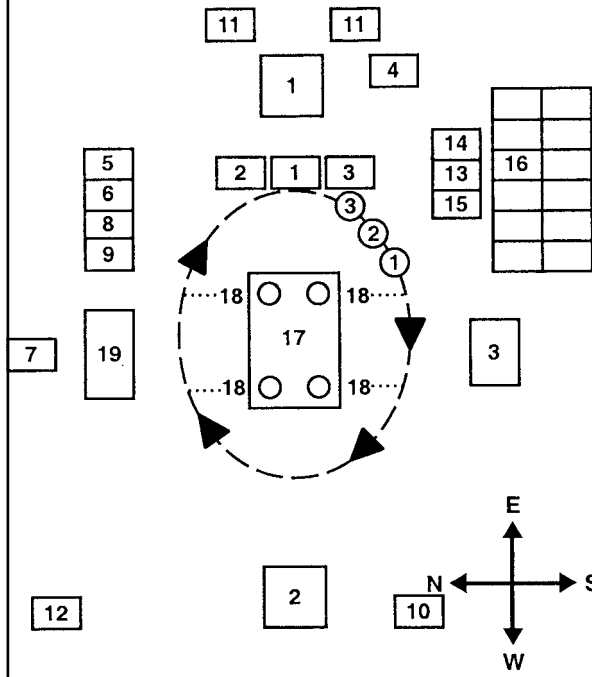

CONSECRATION OF CRAFT LODGE FOURTH CIRCUIT BY C.O.

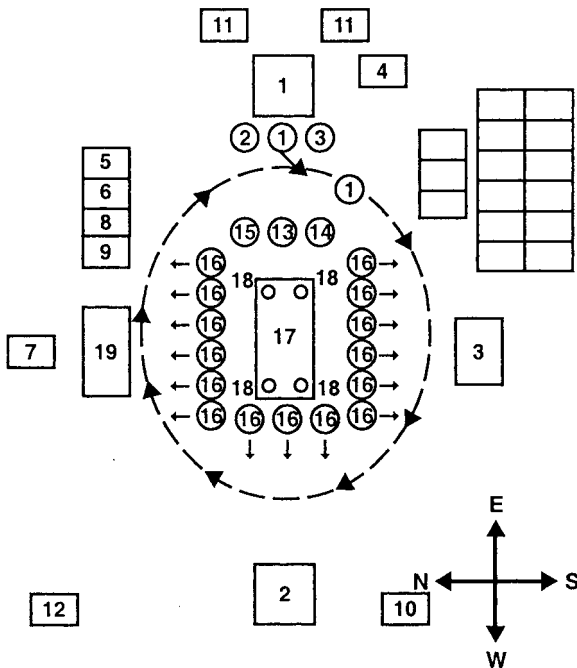

CONSECRATION OF CRAFT LODGE

1st PERAMBULATION BY CHAPLAIN

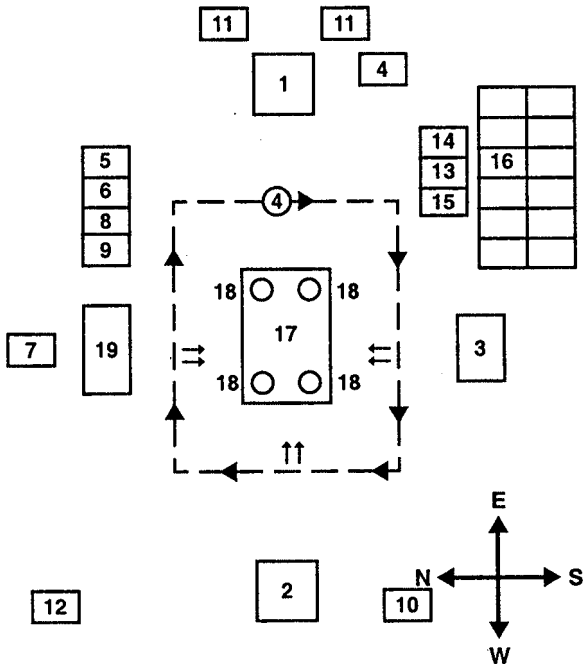

CONSECRATION OF CRAFT LODGE

2nd PERAMBULATION BY CHAPLAIN

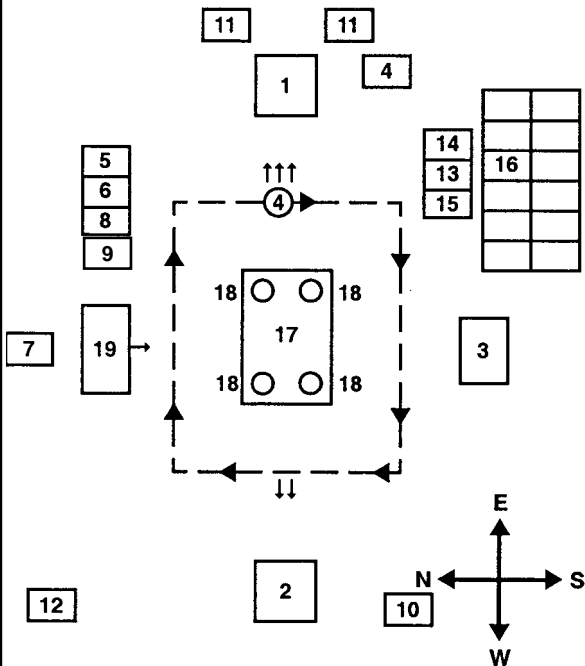

CONSECRATION OF CRAFT LODGE

3rd PERAMBULATION BY CHAPLAIN

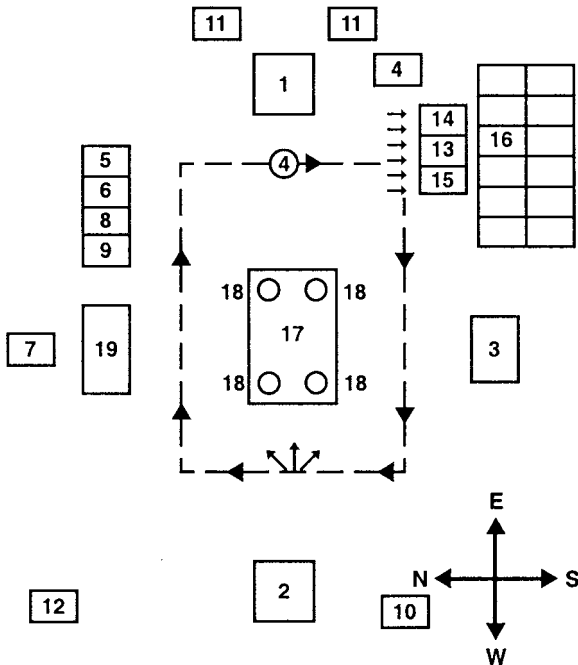

THE CEREMONY OF CONSECRATION OF H.R.A.CHAPTER

General Instructions:

1. Consecrating team is a Supreme Grand Chapter team and shall therefore wear only the Supreme Grand Chapter Regalia.
2. The G.D. of C. will form the ingoing procession in accordance with the seniority of pro-tem office (and not as per the seniority of individual rank)
3. The Consecrating Officer with the assistance of his team will open a casual Chapter. No separate team shall be formed for opening a casual Chapter. The Consecrating Officer, after occupying the M.E.Z. Chair shall appoint the Protem Officers who will bow to the Consecrating Officer and proceed to their respective seats without being escorted.
4. In the opening Ceremony the Consecrating Officer is to be addressed as M.E., and not as M.E. The 1st G.Prin. or M.E. The Grand Supdt., etc.
5. The Consecrating Officer, if he so desires, may address the companions immediately after the Ceremony of consecration, but before he hands over the charge to the Installing Officer.
6. As the Consecrating Officers are relieved of their pro-tem offices, they will be seated on the dais at the right in accordance with their seniority and Regalia they are wearing.

7. After the Installation, the 1st Principal should request any P.Z. to act as I.P.Z., but will not invest him.
8. Companions will remain standing during the four Circuits and Censing of the Chapter right up to the Benediction Prayer.
9. The Treasurer and Janitor should be elected before the Investiture of Officers of the Chapter is taken up.
10. The Bye-Laws of the Chapter should be adopted in open Chapter.
11. The G.D. of C, shall form the out going procession in accordance with the Seniority and the Regalia worn by Consecrating Officers.

Requisites:

1. All normal properties and furniture of a Chapter.
2. Consecrating vessels and censer (to be procured from respective R.G.C.)
3. Consecrating elements - Corn, Wine, Oil and Salt.
4. Incense, Camphor and Match box.
5. One small table for Consecrating Vessels.
6. Four Saucers.
7. Four small corner Tables for placing Saucers.
8. Charter or Warrant.

9. Book of R.A. Regulations, Regional Grand Chapter Bye-Laws and draft bylaws of the Chapter.
10. Oil for the Installation Ceremony.

Seating Arrangement:

1. Seats on the dais at the right of Consecrating Officer.
2. Two Seats in North-East for the G. D. of C. and the Dy. D of C.
3. Seats for the petitioners in South-East and for the Three Principals designate in front.

CEREMONIAL

- D. of C *(At the door of the Chapter):* Upstanding Companions, to receive the Consecrating Principal, M.E. Comp..... accompanied by the Consecrating Officers.

(The Consecrating Officers, Juniors leading, enter in pairs, open out, halt and turn inwards. The Consecrating Principals open the Chapter. The Consecrating 1st Principal appoints the Officers, protem. Each in turn bows and proceeds direct to his place, unescorted. The Lights are not lit and the Altar is not unveiled.)

C.1st Prin: Companions, we have assembled for the laudable purpose of consecrating a new Chapter of Royal Arch Masons so that it may act as a regular Chapter and exalt candidates for Royal Arch Masonry and perform rites and ceremonies conformably with our antient charges and the constitutions of the order. We are pleased and happy to have the opportunity to welcome this addition to our family. Before I proceed with the Ceremony of Consecration, I call upon the Consecrating 3rd principal to give the opening prayer.

D. of C: To order Companions. (*Companions stand with Sn. of R.*)

Prayer

C.3rd Prln.: O Lord, our Heavenly Father, Architect and Ruler of the Universe, who dost from Thy throne behold all the dwellers upon earth, direct us in all our doing with Thy most gracious favour and further us with Thy continual help, that in all our works begun, continued and ended in Thee, we may glorify Thy Most Holy Name.

Omnes : S.M.I.B.

G.D. of C: Be seated Companions.

G. D. of C. (*proceeds to West (no sn.), and addresses the C.1st Prin.*):

Most Excellent the C.O., a number of Companions who are well skilled in the mysteries of the Order, and are now assembled, have requested me to inform you of their gratitude, that you, M.E. the First Grand Principal, have been pleased to grant them a Charter or a Warrant of Constitution, bearing (date)....., corresponding to the..... day of Saka Era, authorizing them to form and open a new Royal Arch Chapter, to be known as Chapter ____ bearing No.....on the Register of the Supreme Grand Chapter of India to meet at in the region of Northern/Southern / Eastern / Western India and are desirous that the Chapter be consecrated and their officers, invested and installed, according to the ancient usages and established customs of the Order, for which purpose they are here assembled and await your pleasure.

(If someone other than M.E. The I.G. Prin is the C.P., then the words "you, M.E. The I.G.Prin." shall be substituted by "ME the I.G. Prin." and instead of the word "have" the word "has" shall be substituted)

C.1st Prin.: I will thank the Companions who have signed the Petition to stand in the body of the Chapter whilst the Grand Scribe 'E.' reads the Warrant or Charter.

D. of C: The Petitioners will stand in the West, the First Principal-Designate in the front, the Second Principal-Designate on his right, the Third Principal-Designate on his left, and the other Petitioners formed behind, all facing East.

(G. D. of C. goes to the three Principals-Designate and leads them to their places, the others following. He gives the Warrant to C. 1st Prin. for inspection and returns it to the Grand Scribe E., who reads it aloud.)

C.1st Prin.: After due consideration, I, as the First Grand Principal, by virtue of the authority vested in me by the Supreme Grand Chapter of Royal Arch Masons of India, have granted to the Companions of this New Chapter, a Warrant establishing in them all the rights and privileges of our Order and I must now enquire of the petitioners whether they approve of the officers named in the warrant to preside over them.

(If someone other than ME The I.G. Prin. is the C.O., then for the words "I as I.G. Prin. by virtue of the authority vested in me" substitute the words "M.E. The I.G. Prin., by virtue of the authority in him vested" and substitute the word "have" by "has")

(Petitioners other than the Principals-Designate, signify their approval by the Sn. of F.)

C. 1st Prin.: Then we will proceed to constitute these Companions into a Regular Chapter of Royal Arch Masons in accordance with the ancient usage and custom.

G. D. of C. (*leads the three designate to their seats.*): The Petitioners, resume your seats. Be seated comps.

C.1st Prin.: I now call upon the C.3rd Prin. to deliver an oration on the nature and purpose of our institution.

(C.3rd Prin. delivers the oration.)

G. D. of C.: To order companions for the first part of the Dedication Prayer.

G. D. of C. : *To order Comps. with Sn. of R.*

Dedication Prayer – First Part

C.3rd Prin.: Let us pray. Almighty Architect of the Universe, Searcher and Ruler of all worlds, deign from Thy celestial abode, from the realms of light and glory, to bless us in all the purposes of our assembly. We humbly beseech Thee to give us wisdom in all our doings, strength of mind in all our difficulties and the beauty of love and harmony in all our communications.

Permit us, O Thou Author of light and life, Great Source of love and happiness to constitute this Chapter, and now solemnly, to consecrate it to the honour and glory of Thy Most Holy Name.

Omnes: S.M.I.B.

G.D. of C: The Companions will assume an attitude of prayer, turning to the East. (Sn. of R.)

THE INVOCATION

C.1st Prin.: O Thou T.A.L.G.M.H., supreme Thou art in heaven above and earth beneath, who keepeth thy covenant and showeth mercy unto thy servants who bow before Thee with all their hearts.

Let all the people of the earth know that the Lord, he is God, and that there is none else.

Let all the people of the earth know Thy name and revere Thee. Let all the people of the earth know that we have built this house and are consecrating it to Thy service. But will Thou, O God, indeed dwell upon the earth? Behold, the heavens, and the heaven of heavens, cannot contain Thee, how much less this house which we have built?

Yet we implore Thee to heed our prayers and supplications and hearken unto our cry. May Thine eyes be opened towards this house by night as well as by day; and when Thy servants shall pray to Thee from this house, hearken unto their

supplications; hear Thou in heaven, Thy dwelling place, and when Thou hearest, forgive.

Omnes: S.M.I.B.

C.1st Prin.: Let the candles be lit.

(The G. D. of C. lights the candles. C.2nd and 3rd Prins. carrying their scepters unveil the altar).

(The C. Prins. place themselves in the East of the Chapter facing West, the C.2nd Prin. on the right, and the C.3rd Prin. on the left of the C.1st Prin. The G. D. of C. hands the cornucopia filled with corn to the C.1st Prin., the vessel containing wine to the C.2nd Prin. and the vessel containing oil to the C.3rd Prin., bowing to each after he does so.)

The First Circuit

(The C.1st Prin. followed by the C.2nd Prin. and C.3rd Prin. in that order, perambulates round the ensigns saying):

C.1st Prin.: I scatter corn upon this Chapter, the symbol of abundance and plenty. May the good seed of His word sink into the hearts of men, take root and bring forth fruit a hundred fold.

G. D. of C. *(When all three have returned to the East.):* The Companions will sing together.

Musical /
Omnes: “Glory be to God on High.”

The Second Circuit

(The G. D. of C. takes the cornucopia from the C.1st Prin. and hands the vessel containing wine to the C.1st Prin. and hands the vessel containing oil to the C.2nd Prin. and the cornucopia to the C.3rd Prin. bowing to each after doing so. The C.1st Prin., followed by the other prins. as before, perambulates round the ensigns saying)

C.1st Prin.: I pour wine upon the Chapter, the symbol of joy and gladness. May we ever rejoice in the revelation of truth and may virtue flourish as the wine.

G. D. of C. : *(When all three have returned to the East).*
Comps will sing together.

Musical /
Omnes: “Glory be to God on High.”

The Third Circuit

(The G. D. of C. takes the vessel containing wine from the C.1st Prin. and hands that

containing oil to the C.1st Prin.; the vessel containing cornucopia to the C.2nd Prin.; wine to the C.3rd Prin, bowing to each, after doing so. The C.1st Prin., followed by other Prins. as before, perambulates round the ensigns, saying)

C.1st Prin.: I sprinkle oil on this Chapter, the symbol of peace and harmony. May the peace that passeth all understanding descend from heaven upon you and abide with you forevermore.

G. D. of C. : (When all three have returned to the East.) : Comps. will sing together.

Musical/

Omnnes: "Glory be to God on High."

(The G. D. of C. receives the consecrating vessels from the three C. Prins. and replaces them on the table. He then hands the vessel containing salt to the C.1st Prin.)

G.D. of C: The petitioners will stand around the ensigns facing outwards, the three prins. Designate in the East. (see diagram)

(G. D. of C. then leads the three Prins. Designate to their places in the East, the others following)

The Fourth Circuit

(The C.1st Prin. now perambulates alone - see diagram)

C.1st Prin.: I strew salt upon this Chapter, the symbol of fidelity, hospitality and everlasting friendship. May these virtues ever continue to distinguish the members of this Chapter, until time with them shall be no more.

G. D. of C. : (When the C.1st Prin. has returned to the East.)
Comps will sing together.

Musical/

Omnes: "Glory be to God on High."

(G. D. of C. receives the vessel of salt, from the C.1st Prin. and replaces it on the table. The consecrating Principals resume their places.)

G.D. of C: To Order companions.

C.1st Prin.: To the T.A.L.G.M.H. and to His service we dedicate this Chapter (*drop Sn. of R*), also to the memory of the three original Grand Principals under whose auspices, many of our mysteries are said to have had their origin.

Omnes : S.M.I.B.

G. D. of C. (*leads the three Prins. Designate to their places*): Petitioners, resume your places, but remain standing.

(C.3rd Prin. goes to the floor of the Chapter in front of the C.O., bows to him, and waits to receive the censer from the D of C. D of C or Dy. D of C, having previously directed the Janitor to prepare the censer obtains it from him and hands it to him. The C.3rd Prin. perambulates the Chapter three times, waving the censer so as to disperse the incense.)

First Perambulation (Censing the Altar)

The Consecrating J bows to the Consecrating Officer, turns right and proceeds down the Chapter. He passes round the Altar, reciting the words of Scripture

“And Aaron shall burn thereon sweet incense”

and censing the Altar in the manner shown in the diagram, and then returns to his position in front of the Consecrating Officer.

Second Perambulation
(Censing the Consecrating Principals)

The Consecrating J bows to the Consecrating Officer and censes him three times.

He bows again, and still standing in the centre, bows to Consecrating H, censes him twice, bows again. He bows to the Consecrating J's Chair, censes it once, bows, and proceeds round the Chapter reciting the appropriate words.

“Every morning, when he dresseth the lamps, he shall burn incense upon it”

Third Perambulation
**(Censing the Principals of the
new Chapter and the Companions generally)**

The Consecrating J bows to the Consecrating Officer, turns right and halts in front of the Principals of the new Chapter. He bows and censes the Z Designate three times and bows. He then, in the same way, censes the H Designate twice and the J Designate once.

The Consecrating J then moves down the Chapter, reciting the first half of the words,

“And when Aaron lighteth the lamps at even, he shall burn incense”

and halts in the West, facing East. Then, half turning to his right, he bows towards South East to the Companions and censes them once and bows. He then turns left, bows towards North East and censes the Companions on that side of the Chapter once and bows. Lastly he faces east, bows, and censes the Comps. in the East once, and bows. He then proceeds up the side of the Chapter reciting the second half of the words,

“A perpetual incense before the Lord throughout your generation.”

and back to his first position, where he bows again to the Consecrating I. Prin., and returns the censor to the D of C. and returns to his seat. Dy. D of C. takes the censor out of the chapter.

G. D. of C.: To order Companions. *(All stand with Sn. of R.)*

DEDICATION PRAYER – Second Part

C.3rd Prin.: Grant, O Lord, that those who are about to be now invested with the government of this Chapter, may be endued with wisdom to instruct their companions in all their duties. May brotherly love, relief and truth ever prevail amongst its members and may this bond of union increase and strengthen the several Chapters throughout the world.

Bless all our companions, whersoever dispersed over the face of the earth and water, and grant a speedy relief to all who are oppressed and distressed. We especially and affectionately commend to Thy special care and attention all the members of the fraternity. May they increase in knowledge of Thee and love of each other. And finally, may we finish our work here below with Thy approbation and then leave this earthly abode for the heavenly temple above, there to enjoy light, bliss and joy now and for evermore.

Omnes : S.M.I.B.

G. D. of C. : The Petitioners will stand in the West, the three Prins. Designate in front, all facing East. (*G. D. of C. leads the three Principals. Designate to their places the others following*).

C.1st Prin.: By virtue of the power and authority in me vested, by the Supreme Grand Chapter of Royal Arch Masons of India, I hereby constitute and form you, my good companions, into a Regular Royal Arch Chapter under the name and style of Chapter..... No.....in the register of the Supreme Grand Chapter of Royal Arch masons of India; and henceforth we empower you to act as a Regular Chapter and to exalt

candidates into RA Masonry, and to perform all the rites and ceremonies conformably with the antient charges and regulations of the order (*Sn. of R by C. 1st Prin. only*). And may the T.A.L.G.M.H. prosper, direct and counsel you in all your undertakings.

Omnes : S.M.I.B.

G. D. of C.: To order, Comp.s for the Patriarchal Benediction.

Patriarchal Benediction

C.3rd Prin.: May the T.A.L.G.M.H. bless, preserve and keep us for evermore. May He lift up the light of His countenance upon us and give us peace, now and for evermore.

Omnes : S.M.I.B.

(G. D. of C. leads the three Prins-Designate to their seats.)

G. D. of C.: Founders, resume your seats, Be seated companions.

CONSECRATION CEREMONY CONCLUDED

CONSECRATION OF R.A CHAPTER SEATING ARRANGEMENT

		20	

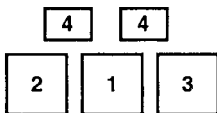

5
6
8

10
9
11

12	

7

16

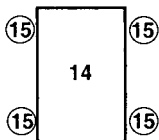

13

19 | 17 | 18

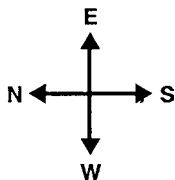

DETAILS OF CONSECRATION OF R.A. CHAPTER:

1. CONSECRATING OFFICER
2. II GRAND PRINCIPAL
3. III GRAND PRINCIPAL
4. GRAND STANDARD BEARERS
5. G.D. OFC
6. DY.G.D. OF C
7. GRAND SCRIBE E
8. GRAND SWORD BEARER
9. M.E.Z DESIGNATE
10. H DESIGNATE
11. J DESIGNATE
12. OTHER PETITIONERS
13. GRAND SCRIBE N
14. ALTAR
15. 4 SAUCERS ON SMALL TABLES
16. SMALL TABLE WITH WHITE CLOTH FOR PLACING
CONSECRATING VESSELS
17. PRIN. SOJOURNER
18. 1ST ASST. SOJOURNER
19. 2ND ASST. SOJOURNER
20. SEATS FOR CONSECRATING OFFICERS

CONSECRATION OF R.A CHAPTER

1st, 2nd and 3rd CIRCUIT BY C.O.

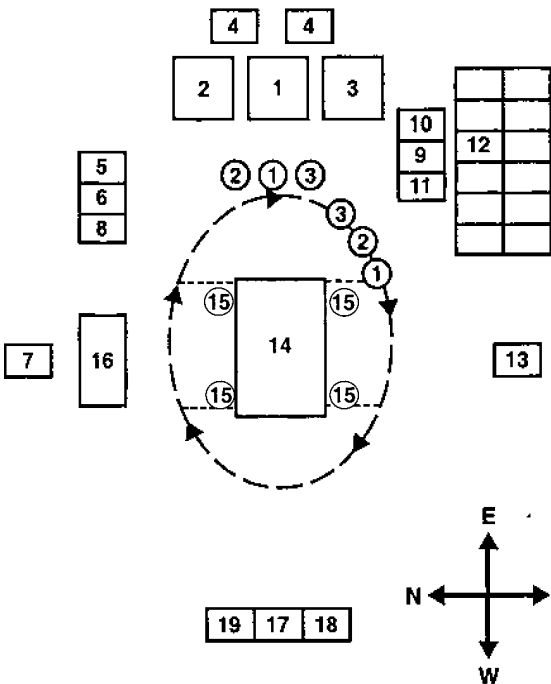

CONSECRATION OF R.A CHAPTER

4th CIRCUIT BY C.O.

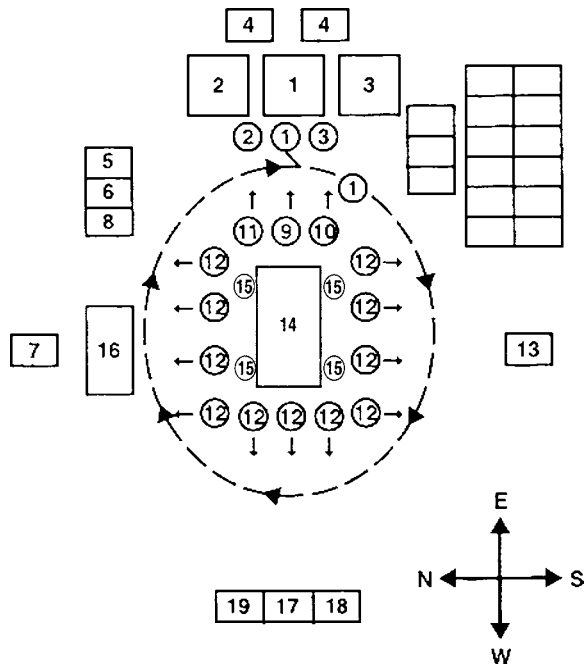

CONSECRATION OF R.A CHAPTER
1st PERAMBULATION BY III GRAND PRINCIPAL

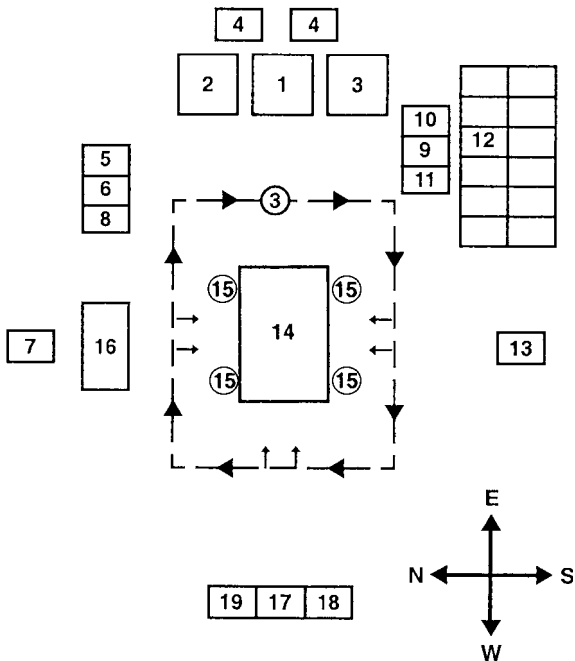

CONSECRATION OF R.A CHAPTER
2nd PERAMBULATION BY III GRAND PRINCIPAL

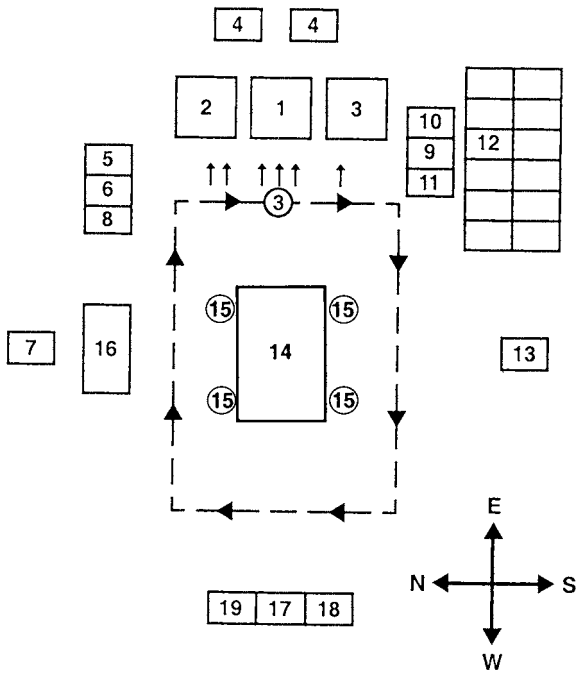

CONSECRATION OF R.A CHAPTER

3rd PERAMBULATION BY III GRAND PRINCIPAL

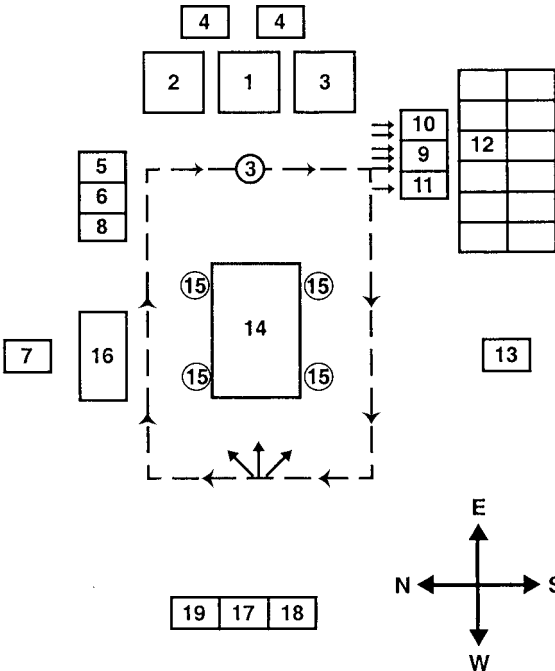

THE CEREMONY OF CONSECRATION OF A MARK LODGE

General Instructions:

1. Consecrating team is a Grand Mark Lodge team and shall therefore wear only the Grand Mark Lodge Regalia.
2. The G. D. of C. will form the ingoing procession in accordance with the seniority of pro-tem office (and not as per the seniority of individual rank).
3. The Consecrating Officer with the assistance of his team will open a casual Mark Lodge. No separate team shall be formed for opening a casual Mark Lodge. The Consecrating Officer, after occupying the Eastern Chair shall appoint the Protem Officers who will bow to the Consecrating Officer and proceed to their respective seats.
4. In the opening Ceremony the Consecrating Officer is to be addressed as W.M., and not as M.W., the Grand Master or R.W., the R.G.M.M., etc.
5. The Consecrating Officer, if so desires may address the brethren immediately after the Ceremony of Consecration, but before he hands over the charge to the Installing Officer.
6. As the Consecrating Officers are relieved of their pro-tem offices, they will be seated on the dais on the right of the W.M., in accordance with their seniority and the regalia they are wearing.

7. After the installation, the W.M. should request any Past Master to act as I.P.M., but will not invest him.
8. Brethren will remain standing during the four Circuits and Censing of the Lodge right up to the Benediction Prayer.
9. The Treasurer and Tyler should be elected before the Investiture of Officers of the Lodge is taken up.
10. The Bye-Laws of the Lodge should be first adopted in open Lodge before they are presented to the newly installed W.M.
11. The G.D. of C., shall form the outgoing procession in accordance with the Seniority and the Regalia worn by Consecrating Officers.

Requisites:

1. All normal properties and furniture of a Mark Lodge.
2. Consecrating vessels and censer (to be procured from respective R.G.Ls.)
3. Consecrating elements - Corn, Wine, Oil and Salt.
4. Incense, Camphor and Match box.
5. Two tables (one large one for the Lodge Board and one small one for the consecrating vessels).
6. Two white table cloths.
7. Four Saucers.
8. Charter or Warrant.

9. Book of Constitutions, Regional Grand Lodges, Draft by Laws of the Lodge.

Seating Arrangement:

1. Seats on the dias at the right of W.M., for Consecrating Officers.
2. Two seats in North-east for the G. D. of C. and his Dy.
3. Seats for the petitioners in South-East. The Master and Wardens designate in front.
4. Overseers chair and pedestals are not to be placed in position during consecration. These should be easily available for placing immediately prior to Installation.

Ceremonial

- G. D. of C. *(At Lodge door):* Upstanding Brethren to receive the C.O., M.W./R.W. Bro..... accompanied by the Consecrating Officers.

(The Consecrating Officers, Juniors leading enter in pairs, open out, halt and turn inwards. The Consecrating Officer (CO.) after occupying his chair appoints his Officers, protem. Each in turn bows and proceeds direct to his place unescorted. The Consecrating Officer opens the Lodge. The Tracing Board is not opened. The G. D. of C. then calls upon the brethren to salute the CO.)

CO. : Brethren, we have assembled here for the laudable purpose of Consecrating a New Mark Lodge and constituting it into a Lodge of Mark Master Masons so that it may act as a Regular Lodge, advance candidates for Mark Masonry and perform rites and ceremonies conformably with our ancient charges and the constitutions of the order. We are pleased and happy to have the opportunity to welcome this addition to our family. Before I proceed with the Ceremony of Consecration, I call upon the Chaplain to give the Opening Prayer.

G.D.of.C.: To Order brethren.

(Brethren stand with the Sn. Of R.)

Chap.: O, G.O.O.T.U., vouchsafe Thy blessing on this our present assembly. Let this Mark Master Masons' Lodge, now about to be consecrated be established to Thy honour and glory. May its officers be endued with wisdom to discern and fidelity to pursue its true interests. May its members be ever mindful of the duty they owe to Thee, O God. Direct them in all their doings with Thy most gracious favour and further them with Thy continual help, that in all their works begun, continued and ended in Thee, they may glorify Thy Most Holy Name.

Omnes : S.M.I.B.

G. D. of C.: Be seated brethren.

G. D. of C. : *(From the front of S.W.'s chair and with no Sn. Addressed the CO.):* Most Worshipful the C.O., a number of brethren duly instructed in the mysteries of Mark Masonry who are now assembled, have requested me to inform you of their gratitude, that you, M.W. The Grand Master, have been pleased to grant them a Charter or a Warrant of Constitution bearing (date)corresponding to the of Saka Era, authorizing them to form and open a Lodge of Mark Master Masons to be known as Mark Lodge..... bearing No..... in the Register of Grand Mark Lodge of India, to meet atin the region of Northern/Southern/ Eastern/Western India, and are desirous that their Lodge be consecrated and their officers invested and installed according to the ancient usages and established customs of the Order for which purpose they are now assembled and await your pleasure.

(Note : If the CO. is someone other than M.W. Grand Master then for the words "Most Worshipful" substitute the words "Right Worshipful" and for the words , "that you, as M.W. The Grand Master, have"

substitute the words “that M.W. The Grand Master, has”.)

CO.: I will thank the brethren who have signed the petition to stand in the body of the Lodge while the Grand Secretary reads the Warrant or Charter.

G. D. of C.: The petitioners will stand in the East, with the Master Designate in front, the Senior Warden Designate on his right, the Junior Warden Designate on his left and the other petitioners formed behind them all facing East.

(The G. D. of C. goes to the Master and Wardens Designate and leads them to their places, the others following. He then shows the Warrant to the CO. and thereafter he hands it over to the Grand Secretary, who reads the Warrant out aloud).

CO. : After due consideration, I as the Grand Master, by virtue of the authority vested in me by the Grand Lodge of Mark Master Masons of India, have granted to the brethren of this New Lodge, a Warrant establishing in them all the rights and privileges of our order, and I must now enquire of the petitioners whether they approve of the Officers named in the Warrant to preside over them.

(If someone other than M.W. the Grand Master is the CO. then for the words "I, as Grand Master of the Grand Lodge of India have by virtue of the authority vested in me" substitute the words "M.W. The Grand Master, by virtue of the authority vested in him as the Grand Master of the Grand Lodge of India has")

(Petitioners, other than the Master and the Wardens Designate, signify their approval by Sn of F.)

CO.: Then we will proceed to constitute these brethren into a Regular Lodge and to consecrate it according to ancient usages and customs.

G.D.of C: *(G. D. of C. leads the Master and Wardens Designate to their seats.)*

Petitioners be seated; be seated brethren.

CO.: I now call upon the Chaplain to deliver an Oration on the nature and purpose of the Institution.

ORATION

(The Chaplain delivers the Oration.)

D. of C: To Order brethren for the first part of the Dedication Prayer. (All stand with Sn. of R.)

DEDICATION PRAYER – First Part

Chap.: Grant, O, Thou Most High, that our chief corner stone may be laid in holiness to the Lord; and when we meet here for the purpose of masonry, may we be guided by the rules and precepts of Thy holy law, and may they lead us through all the scenes of our checkered existence to a house not made with hands, eternal in the heavens. There, may our mysteries harmonize with the practice of our religious duties and guide us to that Grand Lodge above where we hope to meet our brethren in perfect happiness. To Thee, O Most High, we dedicate our work and to Thee, be the Glory.

Omnes : S.M.I.B.

D. of C: The brethren will turn to East and stand to order.
(*All stand to order with Sn. Of R.*)

THE INVOCATION

CO.: O, Lord God, Supreme Thou art, in heaven above and on the earth beneath, who keepeth Thy covenant and showeth mercy unto Thy servants who bow before Thee with all their hearts.

Let all the people of the earth know that the Lord, He is God, and that there is none else.

Let all the people of the earth know Thy name and revere Thee. Let all the people of the earth know that we have built this house and are consecrating it to Thy service. But wilt Thou, O, God, indeed, dwell upon the earth? Behold the heavens and the heaven of heavens, cannot contain Thee; how much less this house that we have built ? Yet we implore Thee to heed to our Prayers and supplications and hearken unto our cry.

May Thine eyes be open towards this house by night as well as by day; and when Thy servants shall pray to Thee from this house, hearken unto their supplications, hear Thou in heaven, Thy dwelling place; and when Thou hearest, forgive.

Omnes : S.M.I.B.

CO. : Let the Lodge Board be uncovered. (*The G. D. of C. uncovers the Board and he or his Deputy takes out the covering cloth.*)

G. D. of C.: Brother Wardens, will you please attend on the Consecrating Officer?

(The CO. places himself on the East of the Lodge Board facing West with the S.W. on his right and the J.W on his left. The G. D. of C. hands the cornucopia filled with corn to the CO., the vessel containing wine to the S.W. and that containing oil to the J.W. bowing to each after doing so.)

THE FIRST CIRCUIT

(The CO. followed by the S.W. and J.W. in that order) perambulates, saying:

“I scatter corn upon this Lodge, the symbol of abundance and plenty, may the good seed of’ His word sink into the hearts of men, take root and bring forth fruit a hundred fold.”

G. D. of C. : *(When all three have returned to east).*
The Brethren will sing together.

Musical/
Omnes:

“Glory be to God on High”.

THE SECOND CIRCUIT

(The G. D. of C. takes the cornucopia from the CO. and hands over the vessel containing wine to the C.O.; the vessel containing oil to the S.W. and the cornucopia to the J.W., bowing to each of them after doing so.)

The CO. *(followed by the wardens as before)* perambulates saying:

“I pour wine upon this lodge, the symbol of joy and gladness. May we ever rejoice in the revelation of truth and may virtue flourish as the wine.”

G. D. of C. : *(When all three have returned to east),*
The Brethren will sing together.

Musical /

Omnes : Glory be to God on High.

THE THIRD CIRCUIT

(The G. D. of C. takes the vessel containing wine from the CO. and hands that containing oil to the CO., the vessel containing wine to the J.W. and the cornucopia to the S.W., bowing to each of them after doing so.)

The CO. *(followed by Wardens as before)*, perambulates saying:

“I sprinkle oil upon this Lodge, the symbol of peace and harmony. May the peace that passeth all understanding descend from heaven upon you and abide with you for evermore.”

G. D. of C. : *(When all three have returned to east)*,
The Brethren will sing together.

Musical /

Omnes: “Glory be God on High”.

(The G. D. of C. receives the consecrating vessels from the CO., the S.W. and J.W. and replaces them on the table. He then hands the vessel containing salt, to the CO.)

D.of C: The petitioners will stand round the Lodge Board, the Master and Wardens Designate in the East, all facing outwards.

(The D. of C then leads the Master Designate to his place, the others following - see diagram)

THE FOURTH CIRCUIT

The CO. now perambulates alone saying:(see diagram)

“I strew salt upon this Lodge, the emblem of fidelity, hospitality and everlasting friendship. May these virtues ever continue to distinguish the members of this Lodge until time with them shall be no more.”

G. D. of C. : *(C.O. returns to the East and stands facing or between SW and JW, as before).* The brethren will sing together.

Musical /

Omnes: “Glory be to God on High”.

(The G. D. of C. receives the vessel of salt from the CO., and replaces it on the table. The CO. and Wardens resume their places.)

G.D. of C: To Order brethren. *(All give Sn. Of R.)*

CO.: To God and his service I dedicate this Lodge *(drop Sn. of R.)* Also to the memory of Adoniram under whose auspices many of our masonic mysteries are said to have had their origin.

Omnes: S.M.I.B.

G.D. of C: Petitioners, resume your places but remain standing.

(The G. D. of C. leads the Master and Wardens Designate to their places. All remain standing. The G. D. of C. or his Deputy having previously directed the Tyler to prepare the censer, obtains it from him. Chap. comes and stands in front of the CO. to receive the censer from the G.D. of C)

Perambulations

(The Chap, perambulations the Lodge three times in a slow march waving the censer so as to disperse the incense, reciting the following words in slow rhythm.)

First Perambulation (Censing the Lodge)

(The Chap, bows to the CO., turns right and proceeds down the Lodge, saying)

“And Aaron shall burn thereon sweet incense”.

(He halts in front of the J.W., faces north and swings the censer twice, slowly walks over to the west, halts in front of the S.W., faces east and swings the censer twice; proceeds in a slow walk along the north, halts opposite and in line with the J.W.'s Chair, faces south and swings the censer twice. He then slowly walks over to the east, halts in front of the CO. and faces him. See Diagram)

Second Perambulation (Censing the CO.)

The Chap. bows to the CO., censes him three times and bows again. He then turns right and proceeds down the Lodge, reciting :

“Every morning, when he dresseth the lamps, he shall burn incense upon it”

(He halts in front of S.W., faces him, bows, censes him twice and bows again. He continues round the lodge until he is in the N., Opposite the J.W. He halts, faces the J.W., bows, censes him once across and over the lodge board and bows again. He then goes back to his position in the E. (see diagram)

Third Perambulation
(Censing the Master and Wardens
Designate, and brethren generally)

(The Chap, bows to the CO., turns right and halts in front of the Master Designate, the S.W. Designate and J.W. Designate in that order on the front row at the East of J.W.'s pedestal. He faces the Master Designate, bows, censes him three times and bows again. He then moves to the front of the S.W. Designate, faces him, bows, censes him twice and bows again. He then moves to the front of the J.W. Designate, faces him, bows, censes him once and bows again. He then proceeds round the Lodge slowly reciting the following words)

“And when Aaron lighteth the lamps at even, he shall burn incense upon it.

(The Chap, proceeds to the West and halts in front of the S.W.'s pedestal facing east, he half turns to his right towards the south-east, bows to the brethren on that side, censes them once and bows again. He next turns left towards North East, bows to the brethren on that side, censes them once and bows again. He finally faces the East, bows, censes the brethren in the east once, he then proceeds onwards along the north reciting the following words, (See Diagram)

“A perpetual incense before the Lord throughout your generation.”

He comes back to his starting position in the East, faces the C.O., bows to him, returns the censer to the G. D of C. and returns to his seat. The G. D. of C. or his Deputy takes the censer out of the Temple.)

G. D. of C.: To order Brethren, for the second part of the Dedication Prayer. *(All stand with Sn. of R.)*

DEDICATION PRAYER – Second Part

Chap: May the Great Overseer, who has promised to bless and preserve all those who truly call upon Him, pour into our hearts the knowledge of truth and virtue, so that when we are brought forth

from the quarries of earthly discipline, we may be found worthy to pass the scrutiny of the Great Master Overseer and be built up as living stones in that spiritual temple not made with hands, eternal in the heavens.

Omnes : S.M.I.B.

G.D. of C: The Petitioners will stand in the West, the Master and Wardens Designate in front, all facing East. *(The G. D. of C. leads the Master Designate to his place, the others following).*

CO.: By virtue of the power and authority in me vested by the Grand Lodge of Mark Master Masons of India, I hereby constitute and form you, my good brethren into a regular Lodge. Henceforth you, are empowered to open and hold a Lodge of Mark Master Masons, to confer that degree and to do and perform all such things as may thereto appertain, strictly by conforming in all your doings to the landmarks of the Order and the regulations of the Grand Lodge of Mark Master Masons of India. I now proclaim this Mark Lodge _____ No. __ in the register of the

Grand Lodge of Mark Master Masons of India to have been regularly constituted and dedicated (*Sn. of R. by C.O. only*). May the G.O.O.T.U. be with you to guide and direct you in all your lawful undertakings.

Omnes : S.M.I.B.

G.D. of C: To order Brethren. (Sn. of R.)

Patriarchal Benediction

Chap. : May the G.O.O.T.U. bless, preserve and keep us evermore, May He lift up the light of His countenance upon us and give us peace, now and for evermore.

Omnes : S.M.I.B.

(G. D. of C leads the Master and Wardens. designate to their places and then announces:)

G. D. of C.: Founders resume your seats.

G. D. of C. : Be seated brethren.

CEREMONY OF CONSECRATION OF MARK LODGE CONCLUDED

CONSECRATION OF MARK LODGE SEATING ARRANGEMENT

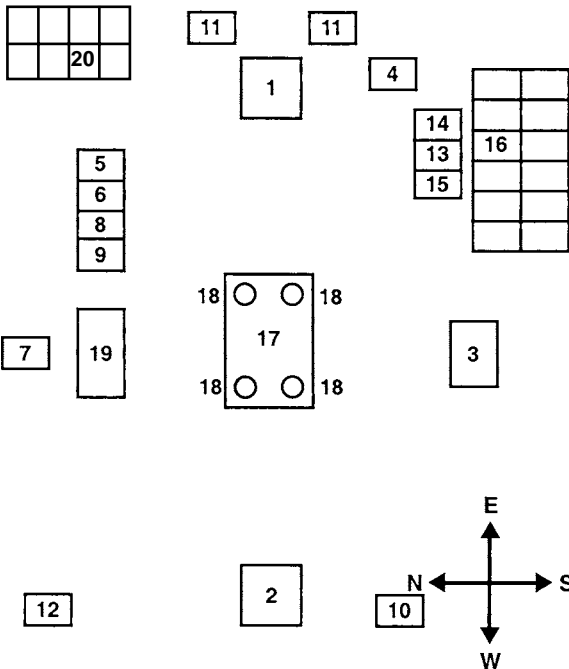

DETAILS OF CONSECRATION OF MARK LODGE:

1. CONSECRATING OFFICER
2. GRAND SENIOR WARDEN
3. GRAND JUNIOR WARDEN
4. GRAND CHAPLAIN
5. G.D. OFC
6. DY.G.D. OF C
7. GRAND SECRETARY
8. GRAND SWORD BEARER
9. GRAND SENIOR DEACON
10. GRAND JUNIOR DEACON
11. GRAND STANDARD BEARERS
12. GRAND INNER GUARD
13. MASTER DESIGNATE
14. S.W. DESIGNATE
15. J.W. DESIGNATE
16. OTHER PETITIONERS
17. CENTRE TABLE WITH LODGE BOARD
18. SAUCERS
19. SMALL TABLE WITH WHITE CLOTH FOR PLACING
CONSECRATING VESSELS
20. SEATS FOR CONSECRATING TEAM

CONSECRATION OF MARK LODGE

1st, 2nd and 3rd CIRCUITS BY C.O.

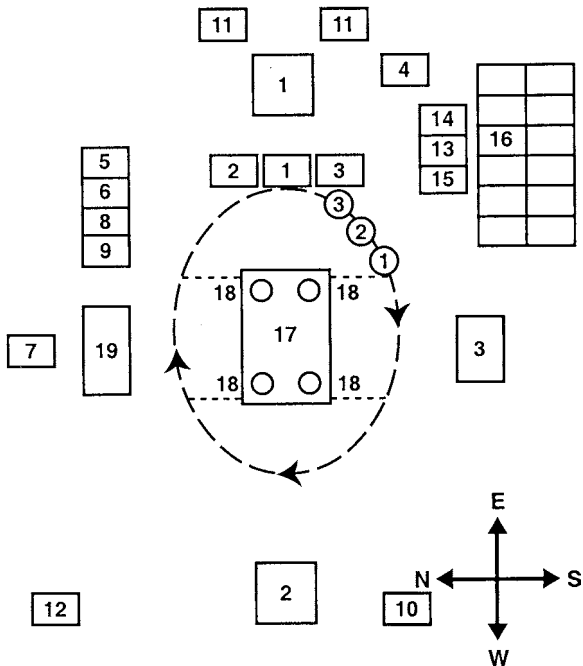

CONSECRATION OF MARK LODGE 4th CIRCUIT BY C.O.

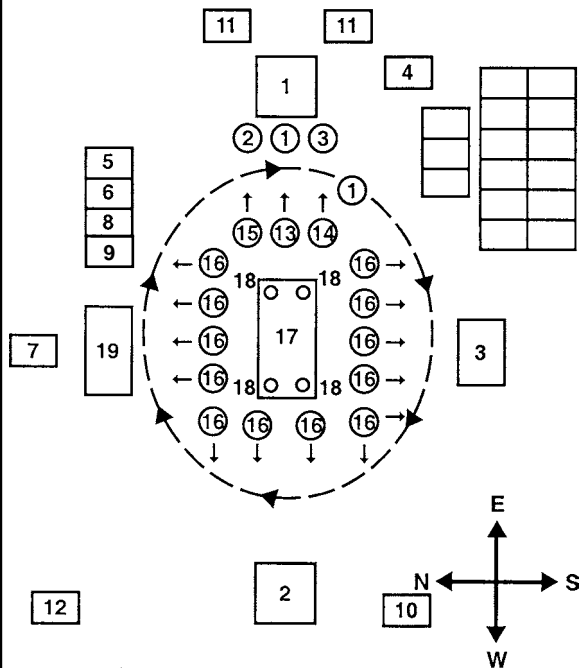

CONSECRATION OF MARK LODGE

1st PERAMBULATION BY CHAPLAIN

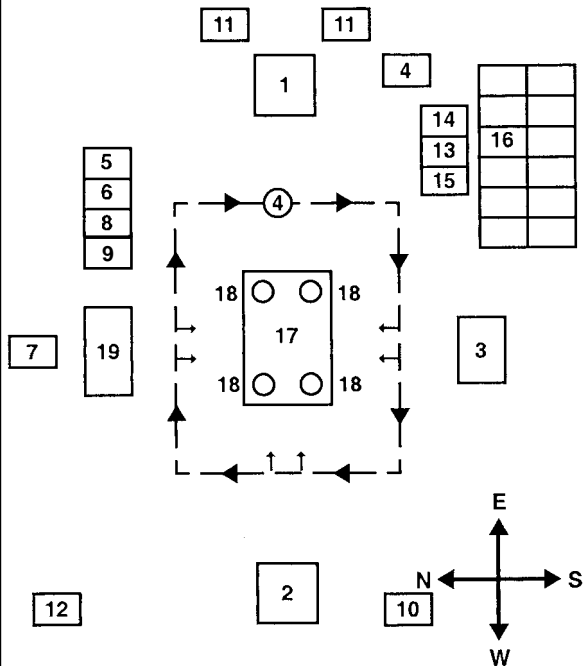

CONSECRATION OF MARK LODGE

2nd PERAMBULATION BY CHAPLAIN

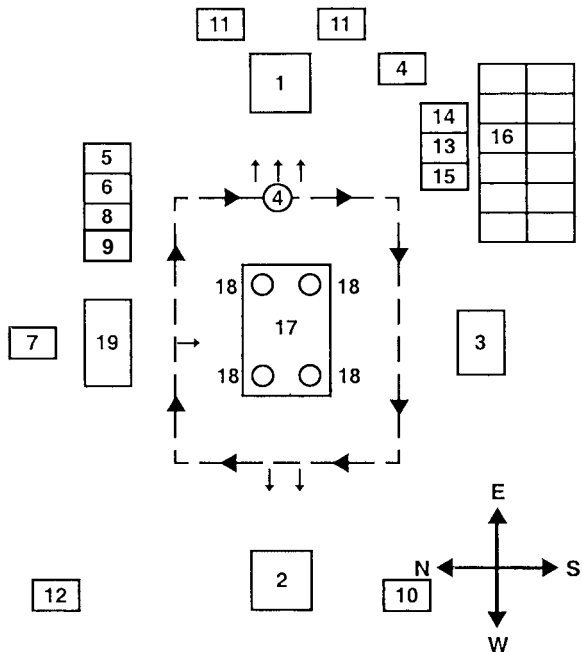

CONSECRATION OF MARK LODGE

3rd PERAMBULATION BY CHAPLAIN

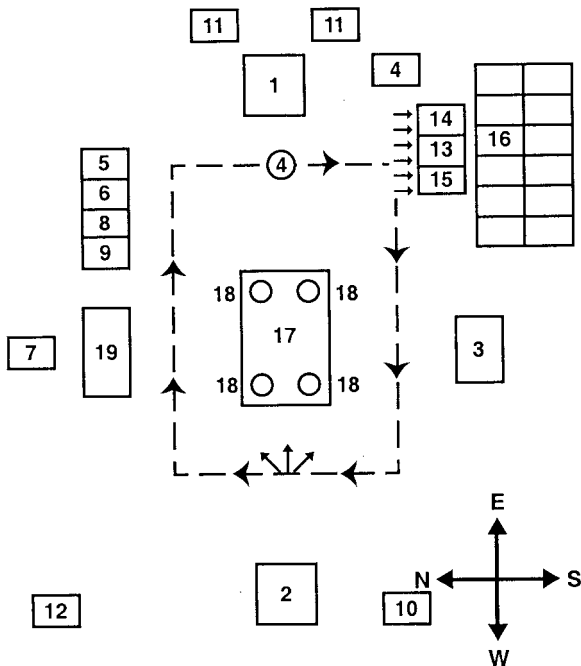

THE CEREMONY OF CONSECRATION OF A ROYAL ARK MARINERS LODGE

General Instructions:

1. The Consecrating team is a Grand Mark Lodge team and shall therefore wear only the Grand Mark Lodge Regalia.
2. The G.D. of C. will form the ingoing procession in accordance with the seniority of pro-tem office and not as per the seniority of individual rank)
3. The Consecrating Officer with the assistance of his team will open a casual R.A.M. Lodge. No separate team shall be formed for opening a casual R.A.M. Lodge. The Consecrating Officer, after occupying the Eastern Chair shall appoint the Protem Officers who will bow to the Consecrating Officer and proceed to their respective seats.
4. In the opening Ceremony the consecrating Officer is to be addressed as W.C.N., and not as M.W., the Grand Master or R.W., the R.G.M.M., etc.
5. The Consecrating Officer if he so desires, may address the brethren immediately after the Ceremony of Consecration, but before he hands over the charge to the Installing Officer.
6. As the Consecrating Officers are relieved of their pro-tem offices, they will be seated on the dais on the right of the W.M. in accordance with their seniority and the regalia they are wearing.

7. After the installation, the W.C.N. should request any Past Commander to act as I.P.C., but will not invest him.
8. Brethren will remain standing during the four Circuits and Censing of the R.A.M. Lodge right up to the Benediction Prayer.
9. The Treasurer and Tyler should be elected before the Investiture of Officers of the Lodge is taken up.
10. The Bye-Laws of the Lodge should be first adopted in open Lodge before they are presented to the newly installed W.C.N.
11. The G.D. of C., shall form the outgoing procession in accordance with the Seniority and the regalia worn by Consecrating Officers.

Requisites:

1. All normal properties and furniture of a R.A.M. Lodge.
2. Consecrating vessels and censer (to be procured from respective R.G.Ls.)
3. Consecrating elements - Corn, Wine, Oil and Salt.
4. Incense, Camphor and Match box.
5. Two tables, one large one for the Mark Lodge Board and one small one for the consecrating vessels.
6. Two white table cloths.
7. Three Saucers with three small tables.
8. Charter or Warrant.
9. Mark Lodge Board.

10. Book of Constitutions of G.M.L.I., Regional Grand Mark Lodge Bylaws, Bylaws of the Lodge (draft).

Seating Arrangement:

1. Seats on the dais at the right of W.C.N, for Consecrating Officers.
2. Two seats in North-east for the G. D. of C. and his Dy.
3. Seats for the petitioners in South-East and for the Commander and Wardens designate in front.

Ceremonial

G. D. of C. *(At Lodge door):* Upstanding Brethren to receive the Consecrating Officer, M.W./R.W. Bro....., accompanied by the Consecrating Officers.

(The Consecrating Officers, Juniors leading enter in pairs, open out, halt and turn inwards. The Consecrating Officer (C.O.) appoints his Officers, protem. Each in turn bows and proceeds direct to his place unescorted. The Consecrating Officer opens the Lodge. The Mark Tracing Board is not opened.)

C.O. : Brethren, we have assembled here for the laudable purpose of Consecrating a new R.A.M. Lodge and constituting it into a Lodge of Royal

Ark Mariners, so that it may act as a Regular Lodge and elevate brethren to the Degree of Royal Ark Mariners and perform rites and ceremonies conformably with our ancient usages and customs of the order as established and laid down by the laws and constitutions of the Grand Lodge of Mark Master Masons of India. We are pleased and happy to have the opportunity to welcome this addition to our family. Before I proceed with the ceremony of consecration, I call upon the Chaplain to give the opening prayer.

G. D. of C.: To order brethren.

(All stand to order with Sn. of R.)

Prayer

Chap.: O Lord our Heavenly Father, Architect and Ruler of the Universe, who dost from Thy throne behold all dwellers upon earth, direct us in all our doings with Thy most gracious favour and further us with Thy continual help that in all our works begun, continued and ended in Thee, we may glorify Thy Most Holy name.

Omnes: S.M.I.B.

G. D. of C.: Be seated brethren.

G. D. of C. : *(from the West, and without sign, addresses the C.O.):* Most Worshipful the C.O., a number of brethren who are well skilled in the mysteries and ceremonies of Royal Ark Masonry, having obtained from you, a Charter or Warrant of Constitution bearing the (date)..... corresponding to the day of, Saka Era authorizing them to form and open a new Lodge of Royal Ark Mariners, to be styled as R.A.M. Lodge No.....moored to Mark Lodge..... No. on the roll of the Antient and Honourable Fraternity of Mark Master Masons of India, are desirous that you should consecrate it, in order that they may be enabled to work as a regular body of Royal Ark Mariners conformably within the ancient usages and customs of . the Order as established and laid down by the laws and constitutions of the Grand Lodge of Mark Master Masons of India for which purpose they are here assembled and await your pleasure.

(If someone other than M.W. Grand Master is the C.O. for the words "Most Worshipful" substitute the words "Right Worshipful" and for the words "obtained from you" substitute the words "obtained from M.W. Grand Master".)

CO. : I will thank those brethren who have signed the Petition to stand in the body of the Lodge while the Scribe reads the Warrant.

G. D. of C.: The Petitioners will stand in the East, the Commander Noah Designate in front, with the S.W. Designate on his right, the J.W. Designate on his left, and the other Petitioners formed behind, all facing East.

(G.D. of C goes to the Commander Noah Designate and leads him to his place, the others following. He hands over the Warrant to the CO. for perusal and then hands it back to the Grand Scribe, who reads the Warrant)

CO.: After due consideration, I, as Grand Master, by virtue of the authority in me vested by the Grand Lodge of Mark Master Masons of India, have granted to the brethren of this new Lodge a Warrant establishing in them all the rights and privileges of our Order and I must now enquire of the Petitioners whether they approve of the officers named in the Warrant to preside over them.

(If someone other than M.W. the Grand Master is the CO. for the words "I, as Grand Master, by virtue of the authority in me" substitute the words

“Most Worshipful Grand Master by virtue of the authority in him” and substitute the word “have” by “has”.

(The Petitioners, other than the Commander Noah and Wardens Designate, signify their approval by the Sn. of F.)

CO.: Then we will proceed to constitute these brethren into a regular Lodge of Royal Ark Mariners and to consecrate it in accordance with ancient usages and customs.

G. D. of C.: Petitioners, resume your seats. *Be seated brethren (G. D. of C. leads the Commander Noah Designate to his seat)*

CO. : I now call upon the Chaplain to deliver an Oration on the nature and purpose of our Institution.

THE ORATION

(Chap, delivers the Oration)

G. D. of C.: To order brethren for the first part of the Dedication Prayer. *(All give Sn. of F.)*

DEDICATION PRAYER, FIRST PART

Chap.: O ! S.C.O.T.U., who has created all things out of nothing and who, for the sin of man, did once let loose the floodgates of the great deep, look down upon us who are about to consecrate

this Lodge to Thy service in commemoration of the miraculous escape of Noah. Endue us with such strength and wisdom from on high that we may show in all our words and actions the beauty of holiness, and be found worthy of that covenant and promise which Thou didst make with Thy faithful servants of old. To Thee, O Lord, we dedicate our works and to Thee be all the glory.

Omnes: S.M.I.B.

G. D. of C.: The brethren will turn to East and stand to order
(*Sn. of R.*)

THE INVOCATION

CO.: O Lord God, Supreme Thou art in Heaven above and on earth beneath, who keepeth the covenant and showeth mercy unto Thy servants who bow before Thee with all their hearts.

Let all the people of the earth know that the Lord, He is God, and that there is none else. Let all the people of the earth know Thy name and revere Thee. Let all the people of the earth know that we have built this House and are consecrating it to Thy service.

But wilt Thou, O God, indeed, dwell upon the earth? Behold the heavens and the heaven of heavens cannot contain Thee, how much less this House that we have built? Yet we implore Thee to heed to our prayers and supplications, and hearken unto our cry.

May Thine eyes be opened towards this House by night as well as by day; and when Thy servants shall pray to Thee from this house, hearken unto their supplications, hear thou in heaven, Thy dwelling place and when Thou hearest, forgive.

Omnes: S.M.I.B.

C.O.: Let the Lodge Board be uncovered. (*G. D. of C. uncovers the Mark Tracing Board and he, or his Deputy takes out the covering cloth.*)

G. D. of C.: Brother Wardens, will you please attend on the Consecrating Officer?

(The CO. places himself to the east of the Lodge Board, facing west with the S.W. on his right and the J.W. on his left. The G. D. of C. hands the cornucopia filled with corn to the CO., the vessel containing wine to the S.W. and that containing oil to the J.W. bowing to each after doing so.)

The First Circuit

C.O. *(followed by the S.W. and J.W. in that order, perambulates saying):* I scatter corn upon this Lodge, the symbol of abundance and plenty. May the good seed of His word sink into the hearts of men, take root and bring forth fruit a hundred fold.

G. D. of C. *(When all three have returned to the east.):* The brethren will now sing together.

Musical/

Omnes: Glory be to God on High.

The Second Circuit

(The G. D. of C. takes the cornucopia from the CO. and hands the vessel containing wine to the CO., the vessel containing oil to the S.W. and the cornucopia to the J.W. bowing to each after he has done so.)

C.O. : *(followed by W.s. as before, perambulates saying):* I pour wine upon this Lodge, the symbol of joy and gladness: May we ever rejoice in the revelation of truth and may virtue flourish as the wine.

G. D. of C.: *(When all three have returned to the east.):*
The brethren will now sing together.

Musical/

Omnes: Glory be to God on High.

The Third Circuit

(The G. D. of C. takes the vessel containing wine from the CO. and hands over that containing oil to him, the vessel containing wine to the J.W. and the cornucopia to the S.W.)

C.O. : *(followed by Ws.as before, perambulates saying):*
I sprinkle oil upon this Lodge, the symbol of peace and harmony. May the peace that passeth all understanding descend from heaven upon you and abide with you forevermore.

G. D. of C. : *(When all three have returned to the east.):* The Brethren will now sing together.

Musical/

Omnes: Glory be to God on High.

(The G. D. of C. receives the consecrating vessels from the CO. and the Wardens, and replaces them on the table.)

G. D. of C.: The petitioners will stand round the Lodge Board in the form of a triangle, Commander Noah and Wardens Designate in the East, all facing outwards.

(The G. D. of C. then leads the Commander Noah Designate to his place, the others following and

stand as per the diagram. (He then hands the vessel containing salt to the C.O.)

THE FOURTH CIRCUIT

C.O. : *(now perambulates alone (see diagram), saying):*
I strew salt on this Lodge, the emblem of fidelity, hospitality and everlasting friendship. May these virtues ever continue to distinguish the members of this Lodge until time with them shall be no more.

G. D. of C.: *(When the C.O. has returned to the E. and stands facings W. between S.W. and J.W. as before):* The Brethren will now sing together.

Musical /

Omnes: "Glory be to God on High".

(G. D. of C. receives the vessel of salt from the CO., and replaces it on the table. The CO. and Wardens resume their places and remain standing.)

G.D. of C: To Order brethren. *(All give Sn. of R.)*

CO.: To God and his service I dedicate this Lodge *(drop Sn. of F.)* Also to commemorate the miraculous escape of Noah and his family from the overwhelming waters.

Omnes: S.M.I.B.

G.D. of C: Petitioners resume your places but remain standing. *(The G. D. of C. leads the W.C.N. Designate to his place. and they remain standing. The G. D. of C. or his Deputy having previously directed the Warder to prepare the censer, obtains it. Chap. Comes and stands in front of the CO. to receive the censer from the D. of C)*

Perambulations

(The Chap, perambulates the Lodge three times in a slow march waving the censer so as to disperse the incense, reciting the following words in slow rhythm.)

First Perambulation (Censing the Lodge)

(The Chap, bows to the CO., turns right and proceeds down the Lodge, saying)

“And Aaron shall burn thereon sweet incense”.

(He halts opposite and in line with S.W. faces North West, swings the censer twice, slowly walks over to the West, halts in front of the Deacons, faces East, swings the censer twice, proceeds in a slow walk along north, halts

opposite and in line with J.W.'s chair, faces south west and swings the censor twice. He then slowly walks over to the East, halts in front of the CO. and faces him. See diagram)

Second Perambulation (Censing the CO.)

The Chap. bows to the CO., censes him three times and bows again. He then turns right and proceeds down the Lodge, reciting:

"Every morning, when he dresseth the lamps, he shall burn incense upon it"

(He halts in front of S.W., faces him, bows, censes him twice and bows again. He continues round the Lodge until he is in the north, opposite the J.W. He halts, faces the J.W., bows, censes him once across and over the Lodge Board, and bows again. He then goes back to his position in the east. See Diagram).

Third Perambulation (Censing the W.C.N. and Wardens Designate, and brethren generally)

The Chap, bows to the CO., turns right and halts in front of the W.C.N. Designate, the S.W. Designate and J.W. Designate in that order

on the front row. He faces the W.C.N. Designate, bows, censes him three times and bows again. He then moves to the front of the S.W. Designate, faces him, bows, censes him twice and bows again. He then moves to the front of the J.W. Designate, faces him, bows, censes him once and bows again. He then proceeds round the Lodge slowly reciting the following words:

“And when Aaron lighteth the lamps at even, he shall burn incense upon it.”

(The Chap, proceeds to the West and halts in front of the Deacons facing E., he half turns to his right towards the south-east, bows to the brethren on that side, censes them once and bows again. He next turns left towards north-east, bows to the brethren on that side, censes them once and bows again. He finally faces the East, bows, censes the brethren in the east once, he then proceeds onwards along the north reciting the following words. See Diagram.)

“A perpetual incense before the Lord throughout your generation.”

(He comes back to his starting position in the east, faces the C.O., bows to him, hands the censer to the G. D. of C. and returns to his seat. The D. of C, or Deputy takes the censer out of the Temple.)

G. D. of C.: To order brethren, with the Sn. of F., for the second part of the Dedication Prayer.

Dedication Prayer, Second Part

Chap.: O thou Great & Glorious Commander of heaven and earth, who of Thy great mercy didst save Noah and his family from the deluge, we humbly beseech Thee to give Thy blessing to those who are here assembled in Thy Holy Name. May this Lodge be established to Thy Honour, may its officers be endowed with wisdom to discern and strength to preserve its truest interests, may its members ever be mindful of the duties they owe to Thee and of their obligations to each other and may we all so pass through the waves of this troubled world, that when we are called there we may find rest in those mansions of bliss where the rainbow ever circles round Thy throne.

Omnes : S.M.I.B.

G. D. of C.: The petitioners will stand in the west, the Commander Noah and Wardens Designate in front, all facing east. *(The G. D. of C. leads the Commander and Wardens Designate to their places and others follow)*

CO.: By virtue of the power and authority in me vested, by the G.L. of M.M. of I, I hereby constitute and form you my good brethren, into a regular Lodge of Royal Ark Mariners. Henceforth you are empowered to open and hold a Lodge of Royal Ark Mariners, to elevate regularly advanced Mark Master Masons as brethren of the Order and to do and perform all such things as may thereto appertain strictly conforming in all your doings to the landmarks of the Order and the laws and regulations of the Grand Lodge of Mark Master Masons and I now proclaim this R.A.M. Lodge..... No..... on the Roll of Grand Lodge of Mark Master Masons of India to have been regularly constituted and dedicated *(Sn. of F by the C.O. only)* and may the blessing of the S.C.O.T.U. be with you to guide and direct you in all your undertakings.

Omnes : S.M.I.B.

G. D. of C.: To order Brethren, with the Sn. of F., for the Patriarchal Benediction.

Patriarchal Benediction

Chap.: May the S.C.O.T.U. bless, preserve and keep us forevermore, may He lift up the light of His countenance upon us and give us peace, now and forevermore.

Omnes : S.M.I.B.

G. D. of C. (*after leading the Commander Noah Designate to his place*): Founders, resume your seats. Be seated brethren.

**CEREMONY OF CONSECRATION OF
R.A.M. LODGE CONCLUDED**

CONSECRATION OF R.A.M. LODGE SEATING ARRANGEMENT

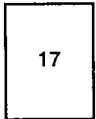
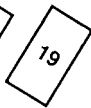
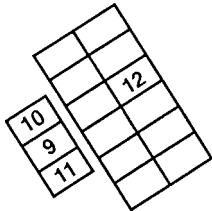
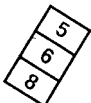
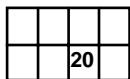

18

18



18



DETAILS OF CONSECRATION OF R.A.M. LODGE

1. CONSECRATING OFFICER
2. GRAND SENIOR WARDEN
3. GRAND JUNIOR WARDEN
4. GRAND CHAPLAIN
5. G.D. OFC
6. DY.G.D. OFC
7. GRAND SCRIBE
8. GRAND SWORD BEARER
9. W.C.N. DESIGNATE
10. S.W. DESIGNATE
11. J.W. DESIGNATE
12. OTHER PETITIONERS
13. JUNIOR DEACON
14. SENIOR DEACON
15. GRAND STANDARD BEARERS
16. GRAND GUARDIAN
17. MARK LODGE BOARD
18. 3 SAUCERS WITH TABLES
19. SMALL TABLE WITH WHITE CLOTH FOR PLACING
20. SEATS FOR CONSECRATING TEAM

CONSECRATION OF R.A.M. LODGE

1st, 2nd and 3rd CIRCUITS BY C.O.

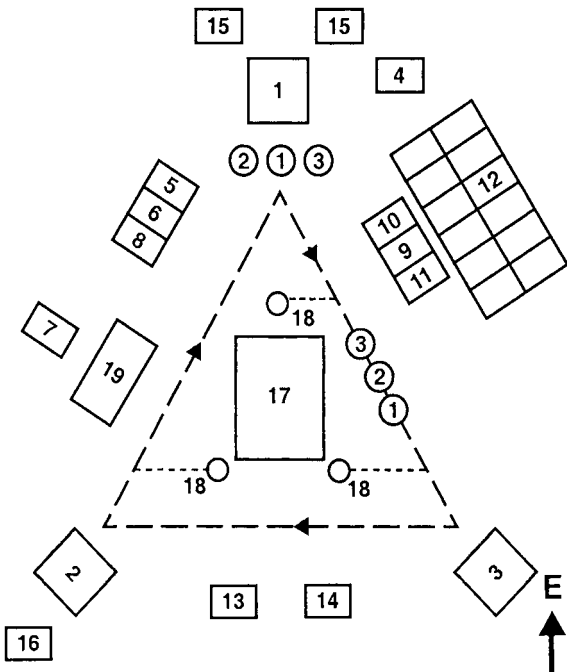

**CONSECRATION OF R.A.M. LODGE
4th CIRCUIT BY C.O.**

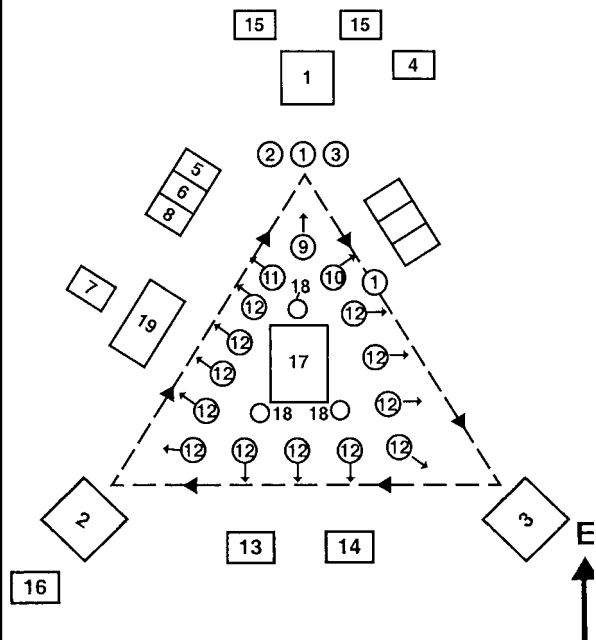

CONSECRATION OF R.A.M. LODGE

1st, PERAMBULATION BY CHAPLAIN

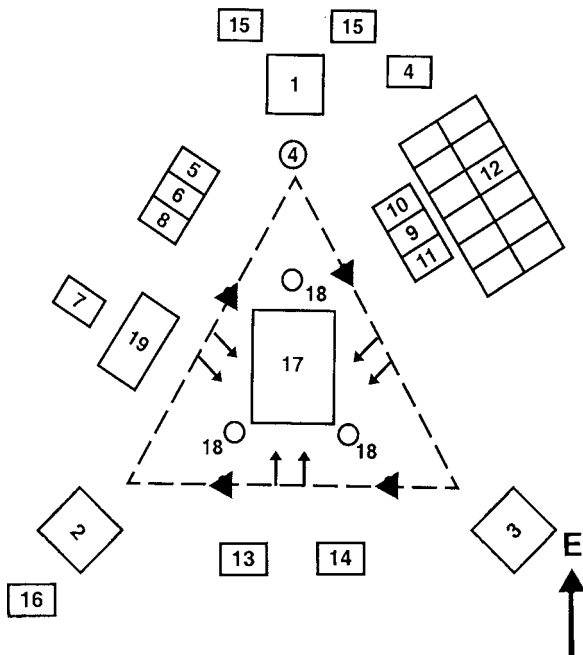

CONSECRATION OF R.A.M. LODGE
2nd PERAMBULATION BY CHAPLAIN

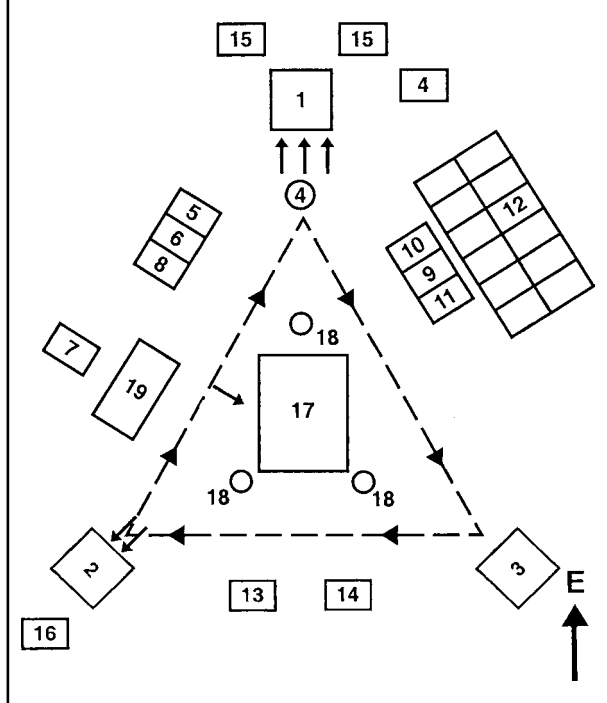

CONSECRATION OF R.A.M. LODGE

3rd PERAMBULATION BY CHAPLAIN

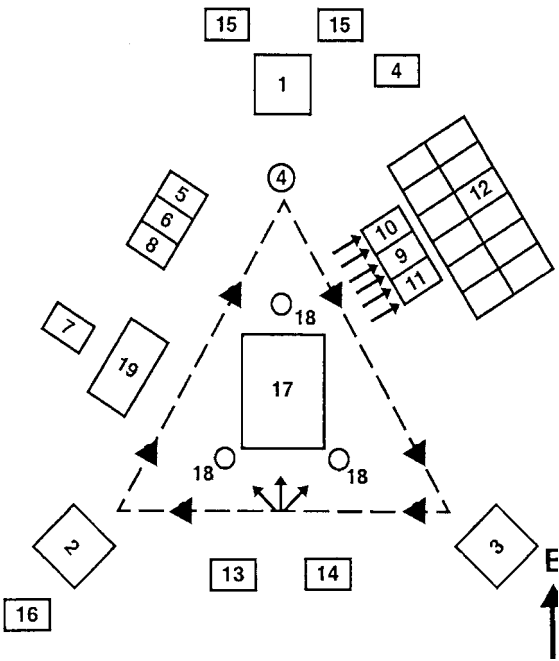

CEREMONY OF DEDICATION OF A LODGE BANNER

General Instructions:

- 1) The Lodge shall be opened in all the Three Degrees.
- 2) R.W. The Regional Grand Master will enter the Lodge in Procession, he will be welcomed, greeted and saluted.
- 3) M.W. The Grand Master (Dedicating Officer) will then enter the Lodge in Procession. He shall be welcomed, greeted and saluted.
- 4) The Lodge shall be closed in Third and Second Degrees.
- 5) The Dedication Ceremony shall be conducted in the First Degree
- 6) The Lodge shall ensure that the Banner contains all the features mentioned in the Explanation as far as possible.
- 7) The Dedicating Officer shall appoint the Grand Wardens and Grand Chaplain to assist him in the Ceremony.
- 8) Brethren remain standing from the opening prayer upto end of dedication prayer. Ceremony of Dedication of a Lodge Banner.

A Senior Past Master of the Lodge or the brother donating the banner says: Worshipful Master it is my very great privilege to invite your acceptance, on behalf of the brethren of the _____ No. _____ on the roll of The G.L.I.) of the Banner about to be unveiled by our beloved M. W. Bro. _____, M. W. The Grand Master. I also request that the banner be then appropriately dedicated for the use of the Lodge, and above all, to the glory of the G.A.O.T.U. without whose divine and special favour, all our works are of no avail”.

The D. of C. forms the procession in front of the I.P.M.’s chair as follows:

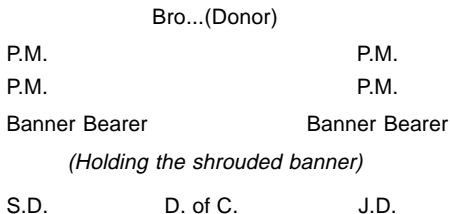

(The procession which commences from the front of I.P.M.’s seat, slowly goes round the Lodge once and proceeds further upto the J.W.’s pedestal and turns inwards towards North and again inwards towards East and proceeds to the East. The procession halts in front of and at a short distance from the W.M.’s pedestal. The banner bearers move ahead and halt in front of the W.M.)

W.M.: W. Bro.....I gladly accede to your request and accept the banner for and on behalf of the brethren of this Lodge No..... on the rolls of the Grand Lodge of India.

(The D. of C, assisted by the two Banner Bearers and Stewards, fixes the banner at its place behind the W.M.'s chair, in readiness for the unveiling. Members of the procession resume their seats.)

W.M.: M. W. The Grand Master, I now request you formally to unveil and dedicate the banner.

(The W.M. then offers the gavel to the D.O. The D.O. occupies the Eastern Chair. The W.M. takes a chair to the left of the D.O. The D.O. requests the Grand Wardens and Grand Chaplain to assume charge. The G.D. of C. places the Grand Wardens and Grand Chaplain in their respective places.)

D.O.: I now call upon the Chaplain for the benefit of prayer.

G. D. of C.: To order brethren. *(All stand with Sn. of R.)*

Prayer

G. Chap.: O Lord our Heavenly Father, Architect and Ruler of the Universe, who dost from Thy throne behold all dwellers upon earth: we beseech Thee to bless

and hallow this banner, which we here consecrate as a symbol of our masonic fellowship, and to the honour and glory of Thy Most Holy Name. Grant to all who gather beneath its shadow, wisdom to teach, humility to learn, and grace to fulfill their obligations. Pour down upon them, and upon all the members of our fraternity, the continual dew of Thy blessings that we may daily increase in love of Thee and one another. And when the earth's fitful day is past, grant unto us a happy passing and a glorious entry into Thy Heavenly Temple, where amid the company of Thy faithful people we may shine as the stars for ever and ever.

Omnes: S.M.I.B.

D.O.: Brethren, you have honoured me by asking me to unveil and dedicate the Lodge banner. I now have the greatest pleasure to unveil the banner of Lodge No..... (*Does so and then continues*). Brethren, a banner is a symbol of faith, a faith which you have voluntarily taken. I strongly exhort you ever to remember your banner and will leave you to your faith.

Brethren, for in as much as men have at all times made for themselves, signs and emblems of their allegiance to their rulers and of their bounden

duty to uphold those laws and institutions which God's providence has called them to obey, we, following this natural and pious custom are met together before God to ask His blessings on this banner which is to represent to us our duty to our Order, our Lodge and to one another. Let us therefore pray to Almighty God to grant that it may never be displayed, save as a symbol of our loyalty to our cause and that true brotherhood for which we stand. May it ever be to those in our Lodge, a sign of His presence with them in all dangers and distresses and increase their faith and hope in Him who is the King of Kings and Lord of Lords.

G. D. of C. : To order Brethren (Sn. of R.)

Almighty Lord, by whose righteous will, all things are, and were created, Thou hast called us into our strong brotherhood of Freemasonry. Deepen the root of our life in everlasting righteousness, make us equal to our high trust, just in the exercise of power and generous in the protection of the weak. May true wisdom and knowledge be the stability of our times and may our deepest trust be in Thee, the Lord of all nations, Thou Creator and Architect of the Universe.

Omnes: S.M.I.B.

DEDICATION

D.O.: In the name of Almighty God, we do dedicate and set apart this banner that it may be a sign of our duty to God and a symbol of our high purpose.

Omnes: S.M.I.B.

G. D. of C. : To order brethren, with Sn. of R.

DEDICATION PRAYER

G. Chap: G.A.O.T.U., we pray Thee, strengthen Freemasonry throughout the world. Especially we beseech Thy blessing upon this Lodge. May the officers and members ever keep in mind their solemn vows and so dedicate themselves to the honour and glory of Thy Holy Name.

Omnes: S.M.I.B.

G. D. of C.: Be seated brethren.

(The D.O. hands over charge of the lodge to the W.M. and resumes his seat at the right of the W.M. The G.D. of C. escorts the Grand Wardens and Grand Chaplain to their seats. The Senior and Junior Wardens of the Lodge take their places.)

D of C. : *(If W.M. is not giving an explanation of the banner, then D. of C. says.)*

May I with your permission, request W/ Bro.....
to give a brief explanation of the banner.

Explanation of the Banner by the W.M.

Banners are a necessity in all Masonic Lodges and each banner has some special features to mark its identity. The pillars, the sun and the moon, the square and compasses, the checkered floor, the All-seeing Eye and such other symbols are constituents of a Lodge banner and I need hardly dwell here upon the significance of these symbols. Besides them, there are certain special features of this Lodge banner. *(Here explain the specific features of this banner. If the banner has been presented by anyone, it may be mentioned here.)* Finally, may I submit that in essence, the banner before you, represents the tools in masonry, our urges and aspirations and the masonic resolve in defense of all that is good and sublime and worthy of preserving and sustaining, I therefore conclude with the hope that it will ever remind us and those who follow us to keep on drawing the necessary inspiration from it and prove worthy of the fold.

Brethren, we have now witnessed a ceremony which will have an effect, deep and lasting, as

long as the banner now presented and dedicated is in being or the record of these proceedings remain. We shall record in our minutes an acknowledgement of our gratitude to M. W. The Grand Master, M. W. Bro., for unveiling the banner and for the service of Dedication; and to his officers for assisting him.

The origin of the banner goes back to remote antiquity. Let it ever be the rallying point for members of this Lodge, for it symbolizes loyalty, fidelity and unity. The spirit of unity and concord, of wisdom and beauty, and of true craftsmanship is demonstrated before us in this banner. May it ever remind us of the fraternal affection which does, and ever should, animate masons in all places and at all times. May the symbols illustrated upon it lead us to seek the highest ideals and direct our actions in harmonious relations with all men, and enable us to prove to the world the happy and beneficial effects of our ancient and honourable institution.

**THE CEREMONY OF DEDICATION
OF THE LODGE BANNER CONCLUDED**

DEDICATION OF BANNER OF A LODGE

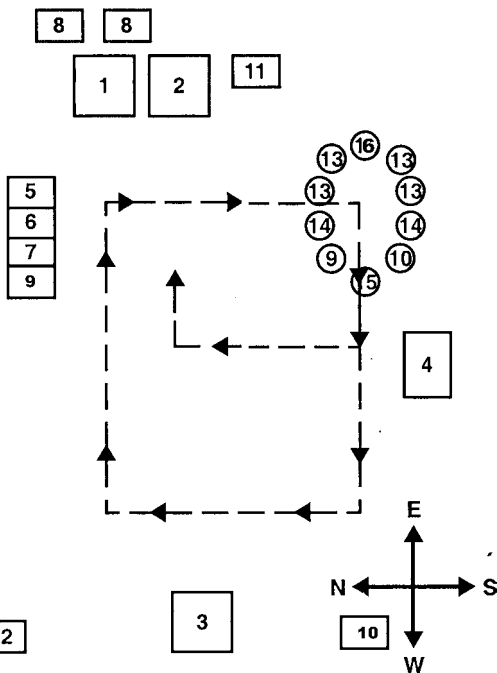

DETAILS OF DEDICATION OF BANNER OF A LODGE:

1. DEDICATING OFFICER
2. W. MASTER
3. SENIOR WARDEN
4. JUNIOR WARDEN
5. G. D. OF C
6. DY. G.D. OF C
7. GRAND SWORD BEARER
8. GRAND STANDARD BEARERS
9. LODGE SENIOR DEACON
10. LODGE JUNIOR DEACON
11. CHAPLAIN
12. LODGE INNER GUARD
13. P.M.s
14. BANNER BEARERS
15. LODGE D. OF C.
16. DONOR

THE CEREMONY OF DEDICATION OF A MASONIC TEMPLE

General Instructions:

- 1) The Lodge shall be opened in all the Three Degrees
- 2) R.W. The Regional Grand Master will enter the Lodge in Procession, he will be welcomed, greeted and saluted.
- 3) M.W. The Grand Master (Dedicating Officer) will then enter the Lodge in Procession. He shall be welcomed, greeted and saluted.
- 4) Before the Ceremony of Dedication, the Lodge shall be closed in Third and Second Degrees. The Dedication Ceremony shall be conducted in the First Degree.
- 5) After M.W. The Grand Master takes charge of the Lodge, he shall appoint Grand Wardens, Grand Chaplain, Grand Inner Guard and Grand Tyler to assist him in the Ceremony of Dedication.

Things Required :

- 1) Consecration Vessels with Corn, Wine, Oil, Salt, Censer, Camphor, Match Box and Four Saucers with Small Tables.

- 2) Table for placing the Consecration Vessels.
- 3) Before the Ceremony, W. Master and R.W. The Regional Grand Master will welcome M.W. The Grand Master(Dedicating Officer).
- 4) M.W. The Grand Master (Dedicating Officer) will address the Lodge before handing over charge of the Lodge back to W. Master after the Ceremony.

CEREMONIAL

W.M. hands over charge of the Lodge to the Dedicating Officer (D.O.) who will appoint his officers and address the brethren as follows:

D.O.: Brethren here assembled to behold this ceremony; be it known, that we, the lawful masons, true and faithful to the laws of our country, and engaged by solemn obligations to revere God, the G.A.O.T.U., are assembled here today in the presence of you all to dedicate this building to the honour and glory of the Most High, which we pray to God, may prosper as it may seem good to Him, and trust that those who enter into it for ceremonial work may go away raised and uplifted. In ordinary circumstances, in consecrating a Lodge we ask God's blessings on the Founders and the Lodge, but tonight we ask His blessings on

this Temple of Lodge..... No.....
on the rolls of the Grand Lodge of India, not only
on the building, for beautiful as it is, it will, in course
of time crumble away to dust, but upon all those
who shall enter here. Before proceeding with the
Ceremony, I call upon the Chaplain to give the
opening prayer.

G. D. of C.: To order brethren, with Sn. of R.

Chap.: Oh Lord, our Heavenly Father, Architect and Ruler
of the Universe, who dost from Thy throne behold
all the dwellers upon earth, direct us in all our doings
with Thy most gracious favour and further us with
Thy continual help, that in all our works begun,
continued and ended in Thee, we may glorify Thy
Most Holy Name.

Omnes: S.M.I.B.

G. D. of C.: Be seated, Brethren.

*(The Chairman of the Building Committee will
present to the D.O., the architect's plans of the
completed structure and give a brief report.)*

D.O.: I thank you, my brother, for the very interesting
account you have given us about this building and
the new Temple. I have examined the plans of the

completed structure which you have placed before me and I am satisfied that the time is ripe for the dedication of this Temple. I also congratulate you and all those who have assisted you on the wonderful results of your work. The work has my fullest approval and it will give me the greatest pleasure to dedicate this Temple.

I will now call on the Chaplain to give us an Oration on the nature and purposes of the Institution.

Oration

The Chaplain delivers an oration.

G. D. of C.: To order brethren, for the Dedication Prayer (*All give Sn. of R.*)

Dedication Prayer

Chap.: Almighty Architect of the Universe, Searcher and Ruler of all worlds, deign from Thy celestial abode, from the realms of light and glory, to bless us in all purposes of our assembly. We humbly beseech Thee to give us wisdom in all our doings, strength of mind in all our difficulties and the beauty of love and harmony in all our communications. Permit us, O Thou Author of light and life, Great Source of love and happiness, to dedicate this Temple and consecrate it to the honour and glory of Thy Most Holy Name.

Omnes: S.M.I.B.

G. D. of C.: Brethren will turn towards the East and stand to order for the Invocation.

Invocation

D.O.: O Lord God, supreme Thou art, in heaven above and on earth beneath, who keepeth Thy covenant and showeth mercy unto Thy servants who bow before Thee with all their hearts.

Let all the people of the earth know that the Lord, He is God, and that there is none else.

Let all the people of the earth know Thy name and revere Thee. Let all the people of the earth know that we have built this House, and are dedicating it to Thy service. But will Thou, O Lord, indeed dwell upon the earth? Behold the heavens and the heaven of heavens, cannot contain Thee; how much less this House that we have built ?

Yet, we implore thee to heed to our prayers and supplications and hearken unto our cry.

May Thine eyes be opened towards this House by night as well as by day; and when Thy servants shall pray to Thee from this house, hearken unto their supplications, hear Thou in heaven, Thy dwelling place, and when Thou hearest, forgive.

Omnes: S.M.I.B.

G. D. of C.: Bro. Wardens, will you please attend on the Dedicating Officer?

(The D.O. places himself in the East, facing West with the S.W. on his right, and the J.W. on his left. The D. of C, hands the cornucopia filled with corn to the D.O., the vessel containing wine to the S.W. and that containing oil to the J.W. bowing to each after he does so.)

First Circuit

D.O. *(followed by S.W. and J.W. in that order, perambulates saying):* I scatter corn upon this Temple, the symbol of plenty and abundance; and may The All Bounteous Creator of the Universe shower His choicest blessings on the members of this community and all who shall assemble in this building to the glory of the Most High, until time shall be no more.

(Arriving at the East, the D.O. and Wardens stand facing west.)

D.O.: I now dedicate this Temple to Freemasonry, to the service of the G.A.O.T.U., to the purposes of that Great Brotherhood which seeks by faith

in God to promote goodwill among men, and to inculcate the purest principles of piety and virtue.

G. D. of C.: The brethren will now sing together.

Musical/

Omnes: Glory be to God on High.

Second Circuit

(The G. D. of C. takes the cornucopia from the D.O. and hands the vessel containing wine to the D.O., the vessel containing oil to the S.W. and the cornucopia to the J.W. bowing to each after doing so.)

D.O. *(followed by the Wardens, as before, perambulates, saying):* I pour wine upon this Temple, the symbol of joy and gladness and may He, whose name is Love grant that we may be all of one heart and mind and may we ever dwell together in peace and unity.

(Arriving at the East, the D.O. and Wardens stand facing West.)

D.O.: I now dedicate this Temple to virtue. May the Symbolism of the Craft and the ceremonies which will be performed within these walls, teach and inspire the practice of every social and moral virtue.

G. D. of C.: The brethren will now sing together.

Musical /

Omnes: Glory be to God on High.

Third Circuit

(The G. D. of C. takes the vessel containing wine from the D.O. and hands the vessel containing oil to the D.O., the vessel containing cornucopia to S.W. and the vessel containing wine to the J.W. bowing to each after doing so.)

D.O. *(followed by Wardens, as before, perambulates, saying):* I pour oil upon this Temple, the symbol of charity and may God give us grateful hearts and may we be ever ready cheerfully to relieve the wants of others.

(Arriving at the East, the D.O. and Wardens stand facing West:)

D.O.: I dedicate this Temple to the cause of universal benevolence. May the principles of Brotherly Love, Relief and Truth lead those who are taught within these walls to act with kindness towards all living creatures.

G. D. of C.: The brethren will now sing together.

Musical /

Omnes: Glory be to God on High.

Fourth Circuit

(The Director of Ceremonies receives the consecrating vessels from the D.O., the Senior Warden and Junior Warden and replaces them on the table. He then hands the vessel containing salt to the D.O.)

D.O. *(now perambulates alone, saying - see diagram)*: I strew salt upon this Temple, the emblem of Hospitality and everlasting friendship and may the all bounteous Author of Nature bless this Town, State, Region and Republic at large with an abundance of Corn, Wine and Oil and all necessaries, comforts and conveniences of life. And may the Almighty Architect of the Universe look down with benignity, upon our present undertaking and crown all the proceedings within this Temple with every success.

(Arriving at the East, the DO stands facing West with Wardens.)

D.O.: I dedicate this Temple to Universal Brotherhood. May the Principles of Fidelity, Hospitality and Friendship ever unite those who are taught within these walls, with the bond of everlasting Friendship and Union.

G. D. of C.: The brethren will now sing together.

Musical /

Omnes: Glory be to God on High.

(The G. D. of C. receives the vessel from D.O. and replaces it on the table. The D.O. and the Wardens resume their places but remain standing. The G. D. of C. having previously directed the Tyler to prepare the censer, gives it to the Chap, who receives it in front of the D.O.'s pedestal. The Chap, takes it three times round the Lodge, waving it so as to disperse the incense, (see Diagram) reciting slowly)

First Perambulation (Censing the Lodge)

(The Chap, bows to the D.O., turns right and proceeds down the Lodge reciting the following words in slow rhythm.)

“And Aaron shall burn thereon sweet incense”.

(He halts in front of the J.W., faces north and swings the censer twice, slowly walks over to the west, halts in front of the S.W., faces east and swings the censer twice; proceeds in a slow walk along the north, halts opposite and in line with the J.W.'s Chair, faces south and swings the censer twice. He then slowly walks over to the east, halts in front of the D.O. and faces him – see Diagram)

Second Perambulation (Censing the D.O.)

(The Chap, bows to the D.O., censes him three times and bows again. He then turns right and proceeds down the Lodge reciting the following words in slow rhythm)

“Every morning when he dresseth the Lamps, he shall burn incense upon it.”

(He halts in front of S.W., faces him, bows, censes him twice and bows again. He continues round the Lodge until he is in the north, opposite the J.W. He halts, faces the J.W., bows, censes him once, and bows again. He then goes back to his position in the east – see Diagram).

Third Perambulation (Censing the brethren generally)

(The Chap, bows to the D.O., turns right and proceeds round the Lodge slowly reciting the following words in slow rhythm)

“And when Aaron lighteth the lamps at even, he shall burn incense upon it.”

(The Chap, proceeds to the West and halts in front of the S.W.'s pedestal facing east, he half turns to his right towards the south-east, bows to the brethren on that side, censes them once and bows again. He next turns left towards north-east, bows to the brethren on that side, censes them once and bows again. He finally faces the East, bows, censes the brethren in the east once, he then proceeds onwards along the north reciting the following words in slow rhythm – see Diagram)

“A perpetual incense before the Lord throughout your generation.”

(He comes back to his starting position in the east, faces the D.O., bows to him, hands the censer to the G. D. of C. and returns to his seat. The G. D. of C. or his Deputy takes the censer out of the Temple.)

G. D. of C.: To order, brethren (Sn. of R.)

Chap.: Grant, O Most High, that all those who shall bear office in this Temple may be endued with wisdom to instruct their brethren in all their duties. Sanctify with Thy grace, all the members of the Fraternity who shall meet here, so that Brotherly Love, Relief and Truth may ever prevail amongst them. And grant that when the labour of this life is ended,

they may leave this earthly abode for Thy Heavenly Temple, there to enjoy light, bliss and joy for evermore.

Omnes: S.M.I.B.

D.O.: We have built Thee a house to dwell in, a settled place for Thee to abide in forever.

G. D. of C. : To order brethren (Sn. of R.)

Benediction

Chap.: May the G.A.O.T.U. bless, preserve and keep us for evermore, may He lift up the light of His countenance upon us, and give us peace, now and forever more.

Omnes: S.M.I.B.

G. D. of C.: Be seated brethren.

**THIS CONCLUDES THE CEREMONY OF
DEDICATION OF MASONIC TEMPLE**

DEDICATION OF TEMPLE SEATING ARRANGEMENT

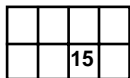

11

11

1

4

5
6
10
8

12 ○

○ 12

7

14

12 ○

○ 12

3

13

2

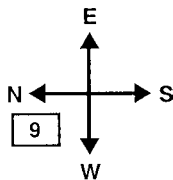

9

DETAILS OF DEDICATION OF TEMPLE:

1. DEDICATING OFFICER
2. GRAND SENIOR WARDEN
3. GRAND JUNIOR WARDEN
4. GRAND CHAPLAIN
5. G. D. OF C
6. DY. G. D OF C
7. GRAND SECRETARY
8. GRAND SENIOR DEACON
9. GRAND JUNIOR DEACON
10. GRAND SWORD BEARER
11. GRAND STANDARD BEARERS
12. FOUR SAUCERS
13. GRAND INNER GUARD
14. SMALL TABLE WITH WHITE CLOTH FOR PLACING
CONSECRATING VESSELS.
15. SEATS FOR DEDICATING OFFICERS.

DEDICATION OF TEMPLE
1st, 2nd and 3rd CIRCUIT BY D.O.

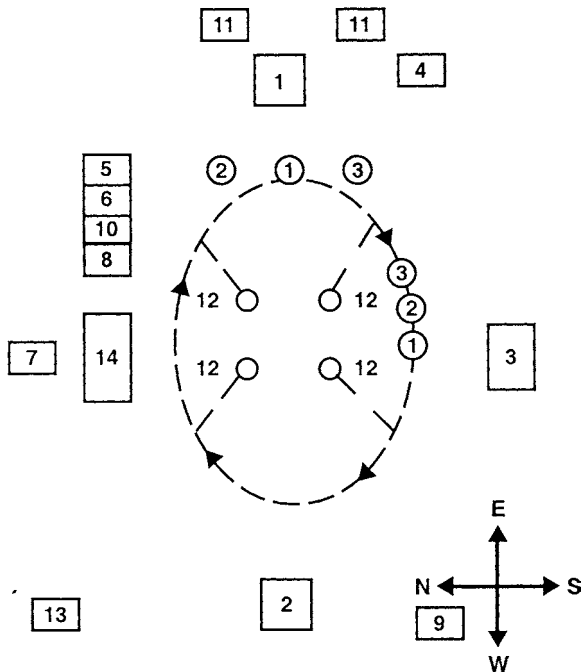

DEDICATION OF TEMPLE

4th CIRCUIT BY D.O.

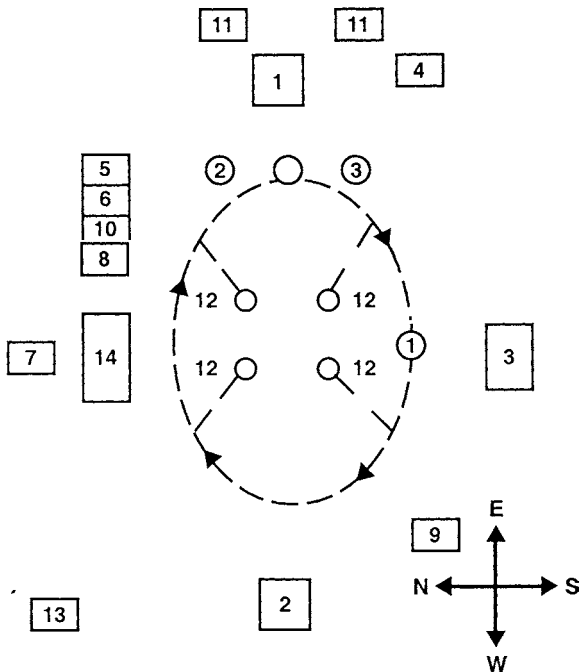

DEDICATION OF TEMPLE

1st PERAMBULATION BY GRAND CHAPLAIN

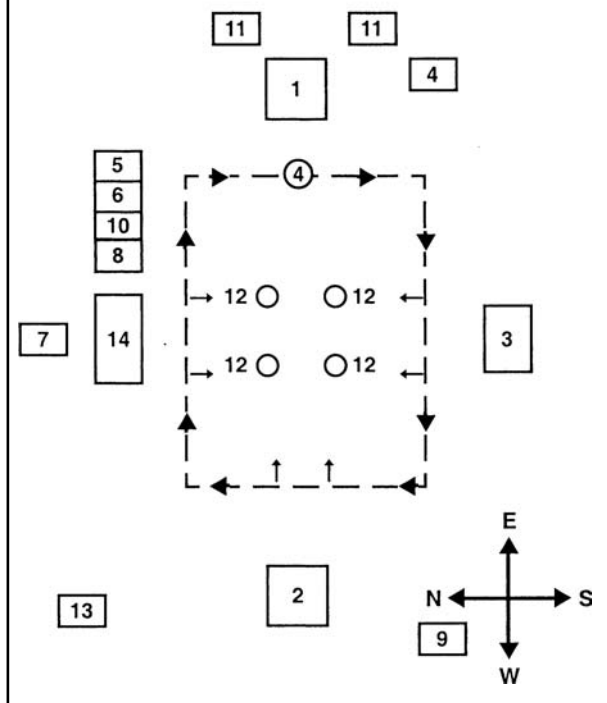

DEDICATION OF TEMPLE

2nd PERAMBULATION BY GRAND CHAPLAIN

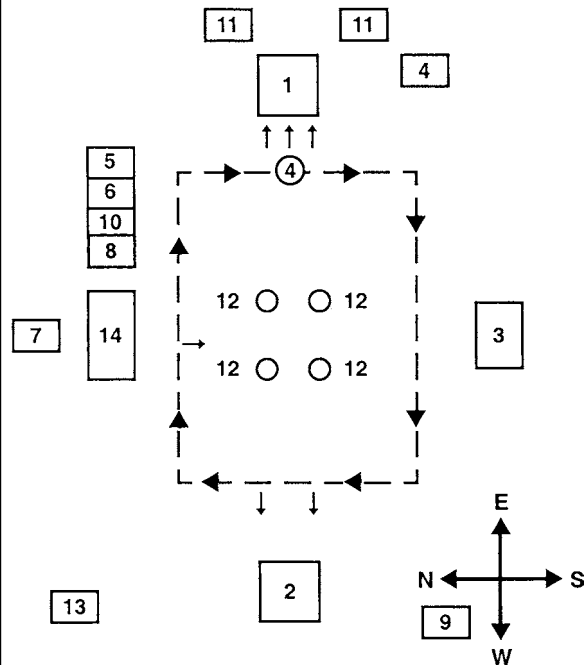

DEDICATION OF TEMPLE

3rd PERAMBULATION BY GRAND CHAPLAIN

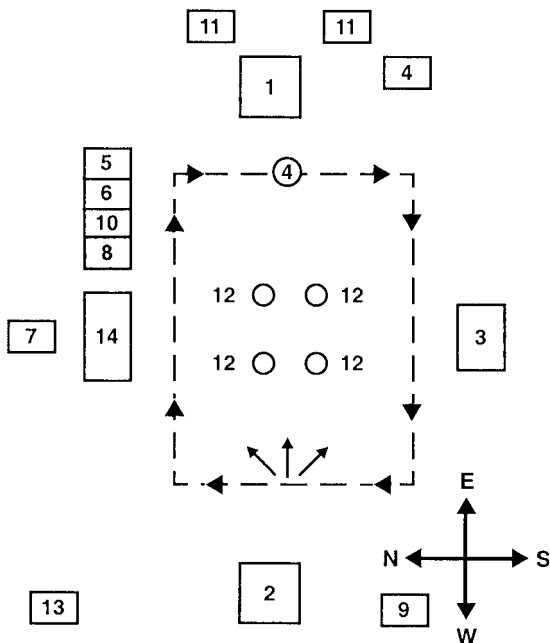

**CEREMONY FOR THE PRESENTATION OF THE
LONG TERM SERVICE JEWEL
FOR 25/40/50/60 YEARS AS A
FREEMASON IN THE CRAFT**

Note:

1. Officer deputed to present the Jewel should be a Grand Officer and should be in his Grand Regalia.
2. Only Masonic record and not other social & cultural activities should be read.

Ceremonial

W.M. : Brethren, we are assembled upon this occasion to pay a tribute of respect and esteem to a distinguished brother of Lodge No. of antient free and accepted masons of India. From time immemorial, Freemasonry has taught a proper reverence and veneration for age. This is particularly so when years of age stand united with years of service and when an honour is conferred upon a recipient who is both worthy and esteemed. Age has always been the crowning glory of man. It affords an opportunity to reflect upon the past and from experiences of the past, the present receives its wisdom, and it is upon wisdom that Freemasonry builds each and every laudable enterprise.

There are three steps which are symbolic of the three principal stages of human life, namely – youth, manhood and age. In youth we may industriously occupy our minds in the attainment of useful knowledge; in manhood we may apply that knowledge to the discharge of our respective duties to God, our neighbour, and ourselves. But it is only in age that we may enjoy the happy reflections consequent upon a life well spent.

It is, therefore, a source of great pride and pleasure that Lodge No.....of Antient Free and Accepted Masons of India has within its midst, upon this occasion, a beloved member who for 25/ 40/50/60 years has been a mason.

Brother Secretary, you will read the full masonic record of Bro.

(Secretary reads the full masonic record of the brother who is to receive the Grand Lodge award. Long Bio-Data including other social achievements to be generally avoided)

Bro. D. of C., you will conduct Bro. to the altar. *(As this is done appropriate music may be played.)*

Bro., it is with pleasure that we behold you before the altar of freemasonry. It was the altar of freemasonry which you were taught to approach 25/ 40/50/60 years ago. There, you assumed obligations which should have made a lasting impression upon your mind and had an uplifting and spiritualizing influence upon your life and character. You have approached the altar of Freemasonry again to receive a recognition which comes to but few men. Heaven has bounteously granted the years of your life and thus you are enabled to receive, as an award from the Most Worshipful Grand Lodge of Free Antient and Accepted Masons of India, a distinguished honour.

As you were taught early in your masonic career never to enter upon any great or important undertaking, without first invoking the blessing of The G.A.O.T.U. I call upon our Chaplain to invoke the blessings of God upon our present convention, that our labours may in all things meet with His approval.

D. of C.: To order brethren.

(The brethren stand with the Sn. of R.)

PRAYER

Chap.: Vouchsafe Thine aid, Almighty Father of the Universe, to this present convention. Grant unto this brother, who has for 25/40/50/60 years been a member of our fraternity, life, health and strength and the daily provisions of Thy good and all-wise providence. Grant, O Lord, we beseech Thee, that when our brother enters into the even tide of his life, he may have rest from every burden, grace to meet every need and receive from Thee an abiding peace that passeth all understanding. May the light of Thy countenance shine upon him, and may faith, hope, and love ever brighten his years. Take not from him Thy Holy Spirit but grant that he may pass the remainder of his life in Thy love and to Thy glory. All of this we ask in the name of the Supreme Architect of the Universe to whom be the glory and honour forever. Amen.

Omnes: S.M.I.B.

D. of C.: Be seated brethren.

(The D. of C. conducts the brother from the altar to right of the W.M.)

W.M.: Brethren, it is now my happy privilege and distinct honour to request M.W./R.W./V.W./Bro....., who for and on behalf

of Most Worshipful The Grand Lodge of Antient Free and Accepted Masons of India, will present the 25/40/50/60 years Grand Lodge award to our brother, whom we are honouring at this time.

Presenting Off.: My brother, within the sacred book of law, which always rests upon our Holy Altar, it is written that the length of life is an award bestowed by the G.A.O.T.U. upon the righteous.

(Optional: The psalmist has declared that the years of our life are three score and ten and if by reason of strength they be four score or more years the additional days are the heritage of those who fear the name of the Lord)

It has been your blessed privilege my brother, to be a mason for 25/40/50/60 years. Therefore, my brother, in recognition of your record as a Freemason for 25/40/50/60 years, the Grand Lodge has seen it fit to present you this jewel as a fitting reward for your 25/40/50/60 years of service to freemasonry.

G. D. of C. : Upstanding brethren.

(All stand but no Sn.)

Presenting Off: My brother, by virtue of the authority in me vested, it is now my happy privilege, for and on

behalf of Most Worshipful The Grand Lodge of Antient Free and Accepted Masons of India to invest you with this jewel as a visible token of its fraternal love and grateful appreciation.

(Invests the brother with the emblem).

May you wear this emblem in health, happiness and prosperity always with pleasure to yourself and with honour to the Grand Lodge, your Lodge, and all of the craft wheresoever dispersed. I also present to you the certificate of long term service from the Grand Lodge. We congratulate you upon your high and distinguished recognition.

Bro. Director of Ceremonies, you will conduct our honoured brother to a seat in the east to the left of the Worshipful Master. *(The distinguished brother is seated in an appropriate place of honour to the left)*

G. D. of C.: Brethren, with the permission of the Worshipful Master, I now request you to greet our distinguished brother with one taking the time from me. *(done)*
Be seated brethren.

(Note : The ceremony may be concluded by a response from the honoured brother)

**CEREMONY FOR PRESENTATION OF
LONG TERM SERVICE JEWEL
FOR 25/40/50/60 YEARS TO A COMPANION
OF A ROYAL ARCH CHAPTER**

Note:

1. Officer deputed to present the Jewel should be a Grand Officer and should be in his Grand Regalia.
2. Only Masonic record and not other social & cultural activities should be read.

Ceremonial

M.E.Z.: Companions, we are assembled upon this occasion to pay a tribute of respect and esteem to a distinguished Companion of Chapter.....No.....on the roll of the Supreme Grand Chapter of India. From time immemorial, Royal Arch Masonry has taught a proper reverence and veneration for age. This is particularly so when years of age stand united with years of service and when an honour is conferred upon a recipient who is both worthy and esteemed. Age has always been the crowning glory of man. It affords an opportunity to reflect upon the past and from experiences of the past, the present receives its wisdom, and it is upon wisdom that Royal Arch Masonry builds each and every laudable enterprise.

There are three steps which are symbolic of the three principal stages of human life, namely; youth, manhood and age. In youth we may industriously occupy our minds in the attainment of useful knowledge; in manhood we may apply that knowledge to the discharge of our respective duties to God, our neighbour, and ourselves; but it is only in age that we may enjoy the happy reflections consequent upon a life well spent.

It is, therefore, a source of great pride and pleasure that Chapter.....No..... of the Holy Royal Arch has within its midst, upon this occasion, a beloved member who for 25/40/50/60 years has been a Royal Arch Mason.

M.E.Z.: Companion Scr. E., you will read the full masonic record of Comp.....

(Comp. Sc. E reads the full masonic record of the Companion who is to receive the Supreme Grand Chapter Award. Long Bio-Data including other social achievements to be generally avoided.)

M.E.Z.: Companion Director of Ceremonies, you will conduct Comp.....to the altar. *(As this is done appropriate music may be played.)*

M.E.Z.: Companion....., it is with pleasure that we behold you before the sacred shrine of Holy

Royal Arch Masonry. It was the sacred shrine which you were taught to approach 25/40/50/60 years ago. There, you assumed obligations which should have made a lasting impression upon your mind and had an uplifting and spiritualizing influence upon your life and character. You have approached the sacred shrine once again to receive a recognition which comes to but few men. Heaven has bounteously granted the years of your life and thus you are enabled to receive, as an award from the Supreme Grand Chapter of India, a distinguished honour. As you were taught early in your masonic career never to enter upon any great or important undertaking, without first invoking the blessing of The T.A.L.G.M.H. I call upon our 3rd Principal to invoke the blessings of God upon our present convention, that our labours may in all things meet with His approval.

D. of C.: To order Companions.

(The Companions stand with the Sn. of R.)

Prayer

3rd Principal: Vouchsafe Thine aid, Almighty Father of the Universe, to this present convention. Grant unto this Companion who has for 25/40/50/60 years been a member of our fraternity of the Holy

Royal Arch, life, health and strength and the daily provisions of Thy good and all-wise providence. Grant, O Lord, we beseech Thee, that when our Companion enters into the eventide of his life, he may have rest from every burden, grace to meet every need and receive from Thee an abiding peace that passeth all understanding. May the light of Thy countenance shine upon him, and may faith, hope, and love ever brighten his years. Take not from him Thy Holy Spirit but grant that he may pass the remainder of his life in Thy love and to Thy glory. All of this we ask in the name of the True and Living God Most High to whom be the glory and honour forever. Amen.

Omnes: S.M.I.B.

D. of C.: Be seated Companions.

(The D. of C. conducts the Companion from the altar to right of the M.E.Z.)

M.E.Z.: Companions, it is now my happy privilege and distinct honour to request M. E. Comp....., who for and on behalf of the Supreme Grand Chapter of India, will present the 25/40/50/60 years Supreme Grand Chapter Award to our Companion, whom we are honouring at this time.

Presenting Off.: My Companion, within the sacred book of law, which always rests upon our Holy Altar, it is written that the length of life is an award bestowed by the True and Living God Most High upon the righteous.

(Optional:- The psalmist has declared that the days of our years are three score and ten and if by reason of strength they be four score years, the additional days are the heritage of those who fear the name of the Lord)

It has been your blessed privilege my Companion, to have been a Royal Arch Mason for 25/40/50/60 years. Therefore, my Companion, in recognition of your record as a Royal Arch Mason for 25/40/50/60 years, the Supreme Grand Chapter of India has seen it fit to permit you to wear this jewel as a fitting reward for your 25/40/50/60 years of service to the Holy Royal Arch Chapter.

G. D. of C. : Upstanding Companions.

(All stand but no Sn.)

Presenting Off.: My Companion, by virtue of the authority in me vested, it is now my happy privilege, for and on behalf of the Supreme Grand Chapter of India to invest you with this jewel as a visible token of its fraternal love and grateful appreciation. *(Invests the Companion with the emblem).*

May you wear this emblem in health, happiness and prosperity always with pleasure to yourself and with honour to the Supreme Grand Chapter of India, your Chapter, and all of the Holy Royal Arch wheresoever dispersed. I also present to you the Certificate of Long Term Service from the Supreme Grand Chapter of India. We congratulate you upon your high and distinguished recognition.

Comp. Director of Ceremonies, you will conduct our honoured Companion to a seat in the east to the left of the M.E.Z. (*The distinguished Companion is seated in an appropriate place of honour to the left*).

G. D. of C.: Be seated Companions,

(Note : The ceremony may be concluded by a response from the honoured Companion)

**CEREMONY FOR THE PRESENTATION
OF THE LONG TERM SERVICE JEWEL
FOR 25/40/50/60 YEARS AS
A MARK MASTER MASON**

Note:

1. Officer deputed to present the Jewel should be a Grand Officer and should be in his Grand Regalia.
2. Only Masonic record and not other social & cultural activities should be read.

Ceremonial

W.M.: Brethren, we are assembled upon this occasion to pay a tribute of respect and esteem to a distinguished brother of Mark Lodge..... No..... of the Grand Lodge of Mark Master Masons of India. From time immemorial, Mark Masonry has taught a proper reverence and veneration for age. This is particularly so when years of age stand united with years of service and when an honour is conferred upon a recipient who is both worthy and esteemed. Age has always been the crowning glory of man. It affords an opportunity to reflect upon the past and from experiences of the past, the present receives its wisdom, and it is upon wisdom that Mark Masonry builds each and every laudable enterprise.

There are three steps which are symbolic of the three principal stages of human life, namely; youth, manhood and age. In youth we may industriously occupy our minds in the attainment of useful knowledge; in manhood we may apply that knowledge to the discharge of our respective duties to God, our neighbour, and ourselves. But it is only in age that we may enjoy the happy reflections consequent upon a life well spent.

It is, therefore, a source of great pride and pleasure that Mark Lodge No.....of the Grand Lodge of Mark Master Masons of India has within its midst, upon this occasion, a beloved member who for 25/40/50/60 years has been a Mark Master Mason.

W.M.: Brother Secretary, you will read the full masonic record of Bro.....

(Secretary reads the full masonic record of the brother who is to receive the Grand Mark Lodge award. Long Bio-Data including other Social achievements to be generally avoided.)

W.M.: Brother Director of Ceremonies, you will conduct Bro.....to the altar. *(As this is done appropriate music may be played.)*

W.M.: Brother....., it is with pleasure that we behold you before the altar of Mark Masonry. It was the altar of Mark Masonry which you were taught to approach 25/40/ 50/60 years ago. There, you assumed obligations which should have made a lasting impression upon your mind and had an uplifting and spiritualizing influence upon your life and character. You have approached the altar of Mark Masonry again to receive a recognition which comes to but few men. Heaven has bounteously granted the years of your life and thus you are enabled to receive, as an award from Most Worshipful The Grand Lodge of Mark Master Masons of India, a distinguished honour.

As you were taught early in your masonic career never to enter upon any great or important undertaking, without first invoking the blessing of The G.O.O.T.U. I call upon our Chaplain to invoke the blessings of God upon our present convention, that our labours may in all things meet with His approval.

D. of C.: To order brethren. (*The brethren stand with the Sn. of R.*)

PRAYER

Chap.: Vouchsafe Thine aid, Almighty Father of the Universe, to this present convention. Grant unto this brother, who has for 25/40/50/60 years been a member of Mark Masonry, life, health and strength and the daily provisions of Thy good and all-wise providence. Grant, O Lord, we beseech Thee, that when our brother enters into the eventide of his life, he may have rest from every burden, grace to meet every need and receive from Thee an abiding peace that passeth all understanding. May the light of Thy countenance shine upon him, and may faith, hope, and love ever brighten his years. Take not from him Thy Holy Spirit but grant that he may pass the remainder of his life in Thy love and to Thy glory. All of this we ask in the name of the G.O.O.T.U. to whom be the glory and honour forever. Amen.

Omnes: S.M.I.B.

D. of C.: Be seated brethren.

(The D. of C. conducts the brother from the altar to right of the W.M.)

W.M.: Brethren, it is now my happy privilege and distinct honour to request M.W./R.W./V.W./Bro.....,

who for and on behalf of the Most Worshipful Grand Lodge of Mark Master Masons of India, will present the 25/40/50/60 years Grand Mark Lodge award to our brother, whom we are honouring at this time.

Presenting Off.: My brother, within the sacred book of law, which always rests upon our Holy Altar, it is written that the length of life is an award bestowed by the G.O.O.T.U. upon the righteous.

(Optional:- The psalmist has declared that the days of our years are three score and ten and if by reason of strength they be four score years the additional days are the heritage of those who fear the name of the Lord").

It has been your blessed privilege my brother, to be a Mark Master Mason for 25/ 40/50/60 years. Therefore, my brother, in recognition of your record as a Mark Master Mason for 25/40/50/60 years, the Grand Lodge of Mark Maser Masons of India has seen it fit to permit you to wear this jewel as a fitting reward for your 25/40/50/60 years of service to Mark Masonry.

G. D. of C.: Upstanding brethren. *(All stand but no Sn.)*

Presenting Off.: My brother, by virtue of the authority in me vested, it is now my happy privilege, for and on behalf of the Most Worshipful Grand Lodge of Mark Master Masons of India to invest you with this jewel as a visible token of its fraternal love and grateful appreciation. *(Invests the brother with the emblem)* May you wear this emblem in health, happiness and prosperity always with pleasure to yourself and with honour to the Grand Mark Lodge, your Mark Lodge, and all of the Mark Masonry wheresoever dispersed. I also present to you the certificate of long term service from the Grand Lodge of Mark Master Masons. We congratulate you upon your high and distinguished recognition.

Bro. Director of Ceremonies, you will conduct our honoured brother to a seat in the east to the left of the Worshipful Master. *(The distinguished brother is seated in an appropriate place of honour to the left)*

G.D. of C. : Brethren, with the permission of the Worshipful Master, I now request you to greet our distinguished brother with one round of claps signifying the knocks of this degree taking the time from me. *(done)*

Be seated brethren.

(Note : The Ceremony may be concluded by a response from the honoured brother)

**CEREMONY FOR PRESENTATION OF
LONG TERM SERVICE JEWEL
FOR 25 /40 /50/60 YEARS TO A
BROTHER OF A ROYAL ARK MARINERS LODGE**

Note:

1. Officer deputed to present the Jewel should be a Grand Officer and should be in his Grand Regalia.
2. Only Masonic record and not other social & cultural activities should be read.

Ceremonial

W.C.N.: Brethren, we are assembled upon this occasion to pay a tribute of respect and esteem to a distinguished Brother of R.A.M. Lodge..... No..... on the roll of the Grand Mark Lodge of India. From time immemorial, Royal Ark Masonry has taught a proper reverence and veneration for age. This is particularly so when years of age stand united with years of service and when an honour is conferred upon a recipient who is both worthy and esteemed. Age has always been the crowning glory of man. It affords an opportunity to reflect upon the past and from experiences of the past, the present receives its wisdom, and it is upon wisdom that Freemasonry builds each and every laudable enterprise.

There are three steps which are symbolic of the three principal stages of human life, namely; youth, manhood and age. In youth we may industriously occupy our minds in the attainment of useful knowledge; in manhood we may apply that knowledge to the discharge of our respective duties to God, our neighbour, and ourselves. But it is only in age that we may enjoy the happy reflections consequent upon a life well spent.

It is, therefore a source of great pride and pleasure that R.A.M. Lodge No.....of the Grand Mark Lodge of India has within its midst, upon this occasion, a beloved member who for 25/40/50/60 years has been a Royal Ark Mariner.

W.C.N.: Bro. Scribe, you will read the full masonic record of Bro.....

(Brother Scribe reads the full masonic record of the Brother who is to receive the R.A.M. Lodge Award. Long Bio-Data including other Social achievements to be generally avoided.)

W.C.N.: Bro. Director of Ceremonies, you will conduct Bro.....to the P.S.

(As this is done appropriate music may be played.)

W.C.N.: Brother.....it is with pleasure that we behold you before the P.S. of a Royal Ark Mariners Lodge. It was the P.S. of Royal Ark Mariners Lodge which you were taught to approach 25/40/50/60 years ago. There, you assumed obligations which should have made a lasting impression upon your mind and had an uplifting and spiritualizing influence upon your life and character. You have approached the P.S. of a Royal Ark Mariners Lodge again to receive a recognition which comes to but few men. Heaven has bounteously granted the years of your life and thus you are enabled to receive, as an award from the Grand Lodge of Mark Master Masons of India, a distinguished honour. As you were taught early in your masonic career never to enter upon any great or important undertaking, without first invoking the blessing of Almighty Father and the S.C.O.T.U., I call upon our Chaplain to invoke the blessings of God upon our present convention, that our labours may in all things meet with His approval.

D. of C. : To order Brethren.
(The Brethren stand with the Sn. of R.)

Prayer

Vouchsafe Thine aid, Almighty Father and S.C.O.T.U., to this present convention. Grant unto this Brother who has for 25/40/50/60 years been a member of our fraternity of Royal Ark Mariners, life, health and strength and the daily provisions of Thy good and all-wise providence. Grant, O Lord, we beseech Thee, that when our Brother enters into the eventide of his life, he may have rest from every burden, grace to meet every need and receive from Thee an abiding peace that passeth all understanding. May the light of Thy countenance shine upon him, and may faith, hope and love ever brighten his years. Take not from him Thy Holy Spirit but grant that he may pass the remainder of his life in Thy love and to Thy glory. All of this we ask in the name of the S.C.O.T.U. to whom be the glory and honour forever. Amen.

Omnes: S.M.I.B.

D. of C.: Be seated, Brethren

(The D. of C. conducts the distinguished brother from the P.S. to right of the W.C.N.)

W.C.N.: Brethren, it is now my happy privilege and distinct honour to request M.W. Bro.....,

who for and on behalf of the Grand Lodge of Mark Master Masons of India, will present the 25/40/50/60 years Grand Mark Lodge Award to our Brother, whom we are honouring at this time.

Presenting Off.: My Brother, within the sacred book of law, which always rests upon our Holy Altar, it is written that the length of life is an award bestowed by the upon the righteous.

(Optional: The psalmist has declared that the days of our years are three score and ten and if by reason of strength they be four score years the additional days are the heritage of those who fear the name of the Lord)

It has been your blessed privilege my Brother, to have been a Royal Ark Mariner for 25/40/50/60 years. Therefore, my Brother, in recognition of your record as a Royal Ark Mariner for 25/40/50/60 years, the Grand Mark Lodge of India has seen it fit to permit you to wear this jewel as a fitting reward for your 25/40/50/60 years of service to Royal Ark Masonry.

G. D. of C.: Upstanding Brethren.

(All stand but no Sn.)

Presenting Off.: My Brother, by virtue of the authority in me vested, it is now my happy privilege, for and on behalf of the Grand Lodge of Mark Master Masons of India to invest you with this jewel as a visible token of its fraternal love and grateful appreciation. *(Invests the Brother with the emblem).*

May you wear this emblem in health, happiness and prosperity always with pleasure to yourself and with honour to the Grand Lodge of Mark Master Masons of India, your Lodge, and all of the Royal Ark Mariners Lodges wheresoever dispersed. I also present to you the Certificate of Long Term Service from the Grand Lodge of Mark Master Masons of India.

We congratulate you upon your high and distinguished recognition.

Bro. Director of Ceremonies, you will conduct our honoured Brother to a seat in the East in an appropriate place of honour to the left of the W.C.N. *(The distinguished Brother is seated.)*

G. D. of C.: Be seated brethren.

(Note : The ceremony may be concluded by a response from the honoured Brother)

MEMORIAL SERVICE (OPTION-1)

General Instructions:

1. Seats for M.W. The Grand Master and R.W. The Regional Grand Master, if they are attending the meeting, should be reserved on the right and left respectively of the Worshipful Master.
2. If the Brethren do not find themselves conversant with the various hymns, recorded hymns may be played.
3. Memorial Service can be conducted only for Master Masons and above and not for Fellow Craft Freemason & Entered Apprentice Freemasons.
4. If the roll of Master Masons is very long, a few selected names can be called—particularly of the deceased brother's contemporaries and all those members present.
5. The oration should be given from South-East corner.
6. Candle Bearers and Bearer of Vs of S.L. remain out till D of C conducts them inside.
7. Bearer of Vs of S.L. will carry Vs of S.L. of the faith of the deceased Brother.
8. While retiring the W.M. moves first accompanied by M.W. the Grand Master, R.W. The Regional Grand Master and followed by other Brethren.

9. Tyler's Toast is a solemn toast taken at long table with brethren remaining standing round the table and utilizing a small glass containing wine or any other dark coloured soft drink not exceeding 50 ml.
10. Black rosettes should be used by all brethren.

CEREMONY OF MEMORIAL SERVICE

PART I – Funeral Procession Entry

All brethren including G.M., R.G.M. & other Grand & R.G.L. officers assemble in the Lodge Room except the brethren who will form the procession. The procession will be formed as under and will enter the Lodge Room. Members of the procession will proceed to their places one by one without being escorted.

A.D. of C.	D. of C,
Tyl.	I.G.
J.D.	S.D.
Sec.	Treas.
Chap.	
P.M.	P.M.
P.M.	P.M.
J.W.	S.W.
I P M	
Swd. Br.	
W.M.	

W.M. : Brethren, we meet this evening to express our grief and sorrow on the sad demise of our beloved M.W./ R.W./V.W./W./ Bro.and to pay a last tribute of respect to the departed mortal. Brethren, assist me to open the Lodge.

The Lodge is opened in the First Degree.

W.M. : Bro. Secretary, you will read the dispensation. *(The dispensation is read.)*

Bro. Sec., you will now read the Summons convening the especial Meeting. *(The Summons are read.)*

Brethren, assist me to open the Lodge in the Second Degree. *(The Lodge is opened in the Second Degree.)*

Brethren, assist me to open the Lodge in the Third Degree. *(The Lodge is opened in the Third Degree.)*

PART II – INTRODUCTION

W.M. : Brethren, let us sing Hymn No.165 (A. & M.) *(All standing. Recording of the Hymn may be played)*

Hymn No. 165 (A. & M.)

O God, our help in ages past
Our hope for years to come;
Our shelter from the stormy blast
And our eternal home.

Beneath the shadow of Thy throne,
Thy Saints have dwelt secure;
Sufficient is Thine arm alone,
And our defense is sure.

Time, like an ever-rolling stream,
Bears all its sons away;
They fly forgotten, as a dream,
Dies at the opening day.

O God, our help in ages past
Our hope for years to come;
Be Thou our guard while trouble fast
And our eternal home.

Calling the Roll (See Note)

W.M.: Bro. Sec., you will call the Roll of Master Masons (*The Roll of living MM's present is called by the Sec. Those present will answer to their names upstanding with the sign of third degree. The name of the deceased brother will be called last. This will be done three times.*)

D. of C.: (Upstanding from his seat) W.M. our beloved brother was summoned to the Grand Lodge above on..... the.....

(Raising and extending the arms to the front at an angle of about 45 degrees, palms of hands inwards, fingers extended, eyes cast upward.)

His spirit hath ascended on high.

(Lowering the arms, hands extended, palms downward to a horizontal position.)

His body, has been solemnly consigned.

(Crossing the arms upon the breast, right hand resting over the heart, left arm over most.)

But his memory we cherish here forever;

(Bowing the head, retaining the arms) S.M.I.B.

W.M.: Brethren, the roll of the workmen has been called, but our M.W./ V.W./ R.W./ W./ Bro. has not answered to his name. He has laid down the working tools of the Craft and with them he has left that mortal part for which he no longer has use. His labours here below have taught him to divest his heart and conscience of the vices and superfluities of Life, thereby fitting his mind as a "Living Stone" for that

Spiritual Building—that house not built with hands – eternal in Heaven. Strengthened in his labours here, by faith in God and confident expectation of immortality, he has sought admission to the Celestial Lodge above.

(All upstanding.)

May his soul rest in peace.

(D. of C. retires and conducts into the Lodge the five Cn. Brs. and the Br. of V.S.L. with lit candles.)

Cn.Br.

Cn. Br.

Cn.Br.

Cn. Br.

Br. of V.S.L.

Cn.Br.

(The candles and the V.S.L are placed on the centre table where the Regalia & Jewels are already placed properly covered in their appropriate position as shown in the diagram. Cn. Brs. go to their seats and remain standing)

The Last Post

(I.G. to give one knock on the door.)

Bugler: The Last Post

Organist: Dead March in “Saul”

(Recording may be used)

W.M.: Brethren, the solemn notes that betoken the dissolution of this earthly tabernacle have again alarmed our outer door, and another spirit has gone before us. Again we are assembled here as masons to offer a tribute of our affection to our beloved brother, and to confirm our faith in the Almighty Father and His beneficent goodness to us, His children.

And may Almighty God of His infinite goodness, at the Grand Tribunal of unbiased justice, extend His mercy towards him and all of us, and crown our hopes with everlasting bliss in the realms of boundless eternity. This we beg for, in the honour of His name, to whom be the glory, now and for evermore.

Omnes : S.M.I.B. (*all sit*)

ORDERING THE LODGE OF SORROW

W.M.: Brethren, the Great Creator having been pleased out of His unbounded mercy, to remove our beloved M.W./R.W./V.W./W./Bro. from the cares and troubles of this transitory existence to a state of everlasting bliss and glory, the chain by which we are united, man to man, has weakened. May we, who survive him, anticipate our approaching fate, and be more firmly cemented in the ties of union and brotherhood, so that, during the short space allotted

to our present existence, we may wisely and usefully employ our time, and in the reciprocal intercourse of kind brotherly acts, mutually promote the welfare and happiness of one another. Sorrow is each man's lot and pain the heritage of all without exception. Where, therefore, shall we find the beauty that shall comfort the universal sorrow, and the understanding that shall put an end to pain? For if we could know that beauty and the meaning of nature's darkest mystery, if not the sorrow, at least its sting would disappear.

W.M.: Brethren, in the midst of life, we are in death; and the wisest knoweth not what the day may bring forth. We live, but to see those we love, passing away into the silent land. Our brother was overtaken by that fate which must sooner or later overtake us all; which neither power nor station, neither virtue nor bravery, neither wealth nor honour, neither efforts of friends nor tears of relatives can avert; teaching us the impressive lesson continually repeated, yet soon forgotten, that each one of us must ere long pass through the valley of the shadow of death, and dwell in the house of darkness. Brethren, we are called upon by the imperious mandate of the dreaded messenger, Death, against whose free entrance within the circle of our fraternity, the barred doors and the Tyler's weapon offer no impediment, to mourn the loss of our brother and do honour to his fond memory.

(All upstanding with Sn. of R.).

PRAYER

Chap.: Most Glorious God; Author of all good, and Giver of all mercy, pour down upon us, Thy sorrowing servants, the consolation of Thy blessing, and strengthen our solemn engagements with the ties of sincere affection. May the present instance of mortality remind us of our approaching fate, and draw our attention towards Thee, the only refuge in times of need, that when the awful moment shall arrive, when we are about to leave this transitory scene, the enlivening prospect of Thy mercy may dispel the gloom of death, and after our departure hence, in peace and in Thy favour, may we be received into Thy Everlasting Kingdom to enjoy in union with the soul of our departed brother, the just reward for a pious and virtuous life, Amen.

Omnes : S.M.I.B.

W.M.: Brethren let us sing Hymn No.262. (*recorded Hymn may be played*)

Hymn No.262 (A & M.)

My God, my father, while I stray,
Far from my home, on life's rough way,
O teach me from my heart to say,
Thy will be done.

Though dark my path and sad my lot,
Let me be still and murmur not,
Or breathe the prayer divinely taught,
Thy will be done.

What though in lonely grief I sigh,
For friends beloved no longer nigh,
Submissive would I still reply,
Thy will be done.

If Thou shouldn't call me to resign,
What most I prize, it ne'er was mine,
I only yield Thee what is Thine,
Thy will be done.

Let but my fainting heart be blest,
With Thy sweet Spirit for its guest,
My God, to Thee. I leave the rest,
Thy will be done.

Renew my will from day to day,
Blend it with Thine, and take away,
All that now makes it hard to say,
Thy will be done.

Amen.

RESPONSES

W.M.: What man is he that liveth and shall not see death?
Shall he deliver his soul from the hands of death?

Omnes: Surely, every man walketh in a vain shadow; he heapeth
up riches and knoweth not who shall gather them.

W.M.: When he dieth, he shall carry nothing away. His glory
shall remain.

Omnes: Naked came he into the world, and naked shall he
return.

W.M.: The Lord gave and the Lord hath taken away. Blessed
be the name of the Lord. Let us die the death of the
righteous and let our last end be like his.

Omnes: God is our God for ever and ever; He will be our guide,
even unto death and after.

S.M.I.B.

GRAND HONOURS

(D. of C. and A. D. of C. uncover the jewels and regalia of the deceased brother. (All cross arms over breast, right hand resting over heart left arm over most.)

J.W.: His memory we cherish here.

(All extending arms full length outward and upward, hands open, palms inward, eyes looking up as in the G. or R.Sn.)

S.W.: His soul we commend to God, who gave it.

(All dropping hands, palms against thighs – No Noise)

W.M.: The will of God is accomplished.

Omnes: S.M.I.B. *(All sit)*

W.M.: Brother orator, it devolves upon you to rehearse before us the story of our departed brother. Tell us of his good deeds, enlarge upon his virtue, kindle within us the spirit of gratitude and respect, so that we may justly mourn for that which we have lost, and strive to imitate those virtues. Freemasonry does not sit in

judgement upon the departed; so let us dwell upon his divine attributes as befitting the present proceedings.

Biographical sketch and eulogy

(Should be delivered from the S.E. All upstanding)

W.M.: Brethren, our recollection of our departed brother has been refreshed, and we may now ask ourselves; was he a just and perfect mason, worthy man, unwearied toiler in the vineyard, and possessed of so many virtues as to overcome his faults and short-comings? Answer these questions as masons should.

Omnes: Man judgeth not man. He, whose infinite and tender mercy passeth all comprehension, whose goodness endureth forever, has called our brother hence. Let Him judge.

W.M.: May we be true and faithful, and may we live and die in love.

Omnes: S.M.I.B.

W.M.: May the Lord bless and prosper us, and may all our good intentions be crowned with success.

Omnes: S.M.I.B.

W.M.: Glory be to God in the highest, on earth peace,
goodwill towards men.

Omnes: S.M.I.B. Now and forever more. Amen.

W.M.: Brethren, let us profit by the admonitions of this solemn occasion. Lay to heart, the truths to which we have listened and resolve to so walk, that when we lay down to the last sleep, it may be the privilege of the brethren to strew white flowers upon our last resting place and keep our memory as a pleasant remembrance.

W.M.: Brethren, let us sing Hymn No.27. (A.& M.) *(Recorded Hymn may be played)*

Hymn No. 27 (A. & M.)

Abide with me, fast falls the eventide,
The darkness deepens, Lord with me abide,
When other helpers fail and comforts flee,
Help of the helpless, O abide with me,

Swift to its close ebbs out life's little day,
Earth's joys grow dim, its glories pass away,
Change and decay run all around I see,
O, Thou who changeth not, abide with me.

I need Thy presence ever passing hour,
What but Thy grace can foil the tempter's power?
Who like Thyself my guide and stay can be?
Through cloud and sunshine Lord, abide with me.

I fear no foe with Thee at hand to bless,
Ills have no weight and tears no bitterness,
Where is death's sting, where, grave thy victory?
I triumph still, if Thou abide with me.

Extended Thy grace unto my closing eyes,
Shine through the gloom and point me to the skies,
Heaven's morning breaks and earth's vain shadows flee,
In life, in death, O Lord abide with me,

Amen

W.M.: Let us unite with Bro. Chap. in an Invocation to the Throne of Grace.

D. of C.: To order, brethren. (Sn. of R.)

PRAYER

Chap.: As the sun sets in the West to close the day, and heralds the approach of night, so one by one we shall lie down in the darkness of the tomb, to wait in its calm repose for the time when the heavens shall pass away on a scroll, and man standing in the

presence of the infinite, shall realize the true end of his pilgrimage here below. Let this solemn ceremony be to us the symbol of remembrance of all the virtues of our departed brother and of those who have preceded us to the silent land, the token of fraternal alliance which binds us while on earth, and which we hope will finally unite us in Heaven.

Amen.

Omnes: S.M.I.B.

GRAND HONOURS

(D. of C. and A.D. of C. cover Jewels and Regalia of the deceased brother.)

J.W.: His memory we cherish here.

(All extending arms full length outward and upward, hands open, palms inward, eyes looking up as in the G. or R.Sn.)

S.W.: His soul we commend to God, who gave it.

(All dropping hands, palms against thighs – No Noise)

W.M.: The will of God is accomplished.

Omnes: S.M.I.B.

REVEILLE

(I.G. to give one knock on door.)

Bugler: Reveille

(D. of C. and A.D. of C. extinguish the four candles on the sides. The fifth candle continues to burn.) (All sit)

PART III – ADDRESSES

(Any brother wishing to address the Lodge may do so at this stage; thereafter the W.M.)

RESOLUTION OF SORROW

(Bro. Sec. will move a suitable resolution of sorrow which the brethren will pass upstanding in solemn silence.)

CLOSING THE LODGE

W.M.: Brethren, assist me to close the Lodge in the Third Degree. *(The Lodge is closed in the Third Degree.)*

W.M.: Brethren, assist me to close the Lodge in the Second Degree. *(The Lodge is closed in the Second Degree. J.W. does not say "Happy have we met.....")*

W.M.: Brethren, assist me to close the Lodge. *(The Lodge is closed. The National Anthem is not sung)*

Funeral Procession – Exit (See Note)

(The procession will reach the banquet hall and brethren will take their positions round the table.)

Toast in Memoriam (Optional)

The W.M. will raise a toast: In pious memory of the departed brother. *(No response from the brethren.)*

(After the toast brethren will leave the banquet Hall in a procession in single file led by M.W. The Grand Master, R.W. the R.G.M. and the W.M. and go to the robing room to disrobe.)

MEMORIAL SERVICE (OPTION-2)

General Instructions:

1. Memorial Service (Option-2) is held in public in the presence of Ladies and Gentlemen.
2. Since the Service is held in public, the Lodge is not opened.
3. Before this Memorial Service commences, the D. of C. may give a brief instructions to the audience regarding the procedures.
4. Seats for M.W. The Grand Master and R.W. The Regional Grand Master, if they are attending the meeting should be reserved on the right and left respectively of the Worshipful Master.
5. If the Brethren do not find themselves conversant with the various hymns, recorded hymns may be played.
6. Memorial Service can be held only for Master Masons and above and not for Fellow Craft Freemason & Entered Apprentice Freemasons.
7. If the roll of Master Masons is very long, a few selected names can be called, particularly of the deceased brother's contemporaries and all those members present.
8. The oration should be given from South-East corner.
9. Candle Bearers and Bearers of Vs of S.L. remain out till D of C conducts them inside.

10. Bearer of Vs of S.L. will carry Vs of S.L. of the faith of the deceased Brother.
11. While retiring the W.M. moves first accompanied by M.W. the Grand Master, R.W. The Regional Grand Master and followed by other brethren and visitors.
12. The Tyler's Toast is a solemn toast taken at long table with brethren remaining standing round the table and utilizing a small glass containing wine or any other dark coloured soft drink not exceeding 50 ml.
13. Black rosettes should be used by all brethren.

CEREMONY OF MEMORIAL SERVICE

PART I Funeral Procession Entry

(All brethren including G.M., R.G.M. and other Grand and R.G.L. officers and visitors assemble in the Lodge room except the brethren who will form the procession. The procession will be formed as under and will enter the Lodge room. Members of the procession will proceed to their places one by one without being escorted.)

A.D. of C.
Tyl.
Sec.
S.D.

D. of C.
J.D.
I.G.
Treas.

Chap.

P.M.

P.M.

P.M.

P.M.

J.W.

S.W.

I P M

Sw.Br.

W.M.

W.M.: Brethren, we meet this evening to express our grief and sorrow on the sad demise of our beloved M.W./ R.W./V.W./W./Bro....., and to pay a last tribute of respect to the departed mortal for which purpose I declare the memorial service open. *(Gives one knock followed by S.W., J.W.)*

D. of C.: To order brethren *(D. of C. opens the V's of S.L.)*

PART II – INTRODUCTION

W.M.: Brethren, let us sing Hymn No.165 (A. & M.) *(All standing. Recording of the Hymn may be played.)*

Hymn No. 165 (A. & M.)

O God, our help in ages past
Our hope for years to come;
Our shelter from the stormy blast
And our eternal home.

Beneath the shadow of Thy throne,
Thy Saints have dwelt secure;
Sufficient is Thine arm alone,
And our defense is sure.

Time, like an ever-rolling stream,
Bears all its sons away;
They fly forgotten, as a dream,
Dies at the opening day.

O God, our help in ages past
Our hope for years to come;
Be Thou our guard while trouble fast
And our eternal home.

Calling the Roll (See Note)

W.M.: Bro. Sec., you will call the Roll of Master Masons (*The Roll of living MM's present is called by the Sec. Those present will answer to their names upstanding with the sign of third degree. The name of the deceased brother will be called last. This will be done three times.*)

D. of C.: (Upstanding from his seat) W.M. our beloved brother was summoned to the Grand Lodge above on..... the.....

(Raising and extending the arms to the front at an angle of about 45 degrees, palms of hands inwards, fingers extended, eyes cast upward.)

His spirit hath ascended on high.

(Lowering the arms, hands extended, palms downward to a horizontal position.)

His body, has been solemnly consigned.

(Crossing the arms upon the breast, right hand resting over the heart, left arm over most.)

But his memory we cherish here forever;

(Bowing the head, retaining the arm) S.M.I.B.

W.M.: Brethren, the roll of the workmen has been called, but our M.W./ V.W./ R.W./ W./ Bro. has not answered to his name. He has laid down the working tools of the Craft and with them he has left that mortal part for which he no longer has use. His labours here below have taught him to divest his heart and conscience of the vices and superfluities of Life, thereby fitting his mind as a "Living Stone" for that

Spiritual Building—that house not built with hands – eternal in Heaven. Strengthened in his labours here, by faith in God and confident expectation of immortality, he has sought admission to the Celestial Lodge above.

(All upstanding.)

May his soul rest in peace.

(D. of C. retires and conducts into the Lodge the five Can. Brs. and the Br. of V.S.L. with lit candles.)

Cn.Br.

Cn.Br.

Cn.Br.

Cn.Br.

Br. of V.S.L.

Cn.Br.

(The candles and the V.S.L are placed on the centre table where the Regalia & Jewels are already placed properly covered in their appropriate position as shown in diagram. Cn. Brs. go to their seats and remain standing)

The Last Post

(I.G. to give one knock on the door.)

Bugler: The Last Post

Organist: Dead March in “Saul”

(Recording may be used)

W.M.: Brethren, the solemn notes that betoken the dissolution of this earthly tabernacle have again alarmed our outer door, and another spirit has gone before us. Again we are assembled here as masons to offer a tribute of our affection to our beloved brother, and to confirm our faith in the Almighty Father and His beneficent goodness to us, His children.

And may Almighty God of His infinite goodness, at the Grand Tribunal of unbiased justice, extend His mercy towards him and all of us, and crown our hopes with everlasting bliss in the realms of boundless eternity. This we beg for, in the honour of His name, to whom be the glory, now and for evermore.

Omnes : S.M.I.B. *(all sit)*

Ordering the Lodge of sorrow

W.M.: Brethren, the Great Creator having been pleased out of His unbounded mercy, to remove our beloved M.W./R.W./V.W./W./Bro. from the cares and troubles of this transitory existence to a state of everlasting bliss and glory, the chain by which we are united, man to man, has weakened. May we,

who survive him, anticipate our approaching fate, and be more firmly cemented in the ties of union and brotherhood, so that, during the short space allotted to our present existence, we may wisely and usefully employ our time, and in the reciprocal intercourse of kind brotherly acts, mutually promote the welfare and happiness of one another. Sorrow is each man's lot and pain the heritage of all without exception. Where, therefore, shall we find the beauty that shall comfort the universal sorrow, and the understanding that shall put an end to pain? For if we could know that beauty and the meaning of nature's darkest mystery, if not the sorrow, at least its sting would disappear.

W.M.: Brethren, in the midst of life, we are in death; and the wisest knoweth not what the day may bring forth. We live, but to see those we love, passing away into the silent land. Our brother was overtaken by that fate which must sooner or later overtake us all; which neither power nor station, neither virtue nor bravery, neither wealth nor honour, neither efforts of friends nor tears of relatives can avert; teaching us the impressive lesson continually repeated, yet soon forgotten, that each one of us must ere long pass through the valley of the shadow of death, and dwell in the house of darkness. Brethren, we are called upon by the imperious mandate of the dreaded messenger, Death, against whose free entrance within the circle of our fraternity, the barred doors

and the Tyler's weapon offer no impediment, to mourn the loss of our brother and do honour to his fond memory.

(All upstanding with Sn. of R.).

PRAYER

Chap.: Most Glorious God; Author of all good, and Giver of all mercy, pour down upon us, Thy sorrowing servants, the consolation of Thy blessing, and strengthen our solemn engagements with the ties of sincere affection. May the present instance of mortality remind us of our approaching fate, and draw our attention towards Thee, the only refuge in times of need, that when the awful moment shall arrive, when we are about to leave this transitory scene, the enlivening prospect of Thy mercy may dispel the gloom of death, and after our departure hence, in peace and in Thy favour, may we be received into Thy Everlasting Kingdom to enjoy in union with the soul of our departed brother, the just reward for a pious and virtuous life, Amen.

Omnes : S.M.I.B.

W.M.: Brethren let us sing Hymn No.262. *(recorded Hymn may be played)*

Hymn No.262 (A & M.)

My God, my father, while I stray,
Far from my home, on life's rough way,
O teach me from my heart to say,
Thy will be done.

Though dark my path and sad my lot,
Let me be still and murmur not,
Or breathe the prayer divinely taught,
Thy will be done.

What though in lonely grief I sigh,
For friends beloved no longer nigh,
Submissive would I still reply,
Thy will be done.

If Thou shouldn't call me to resign,
What most I prize, it ne'er was mine,
I only yield Thee what is Thine,
Thy will be done.

Let but my fainting heart be blest,
With Thy sweet Spirit for its guest,
My God, to Thee. I leave the rest,
Thy will be done.

Renew my will from day to day,
Blend it with Thine, and take away,
All that now makes it hard to say,
Thy will be done.

Amen.

RESPONSES

W.M.: What man is he liveth and shall not see death? Shall he deliver his soul from the hands of death?

Omnes: Surely, every man walketh in a vain shadow; he heapeth up riches and knoweth not who shall gather them.

W.M.: When he dieth, he shall carry nothing away. His glory shall remain.

Omnes: Naked came he into the world, and naked shall he return.

W.M.: The Lord gave and the Lord hath taken away. Blessed be the name of the Lord. Let us die the death of righteous and let our last end be like his.

Omnes : God is our God for ever and ever ; He will be our guide, even unto death and after.

S.M.I.B.

GRAND HONOURS

(D. of C. and A. D. of C. uncover the jewels and regalia of the deceased brother All cross arms over breast, right hand resting over heart left arm over most.)

J.W.: His memory we cherish here.

(All extending arms full length outward and upward, hands open, palms inward, eyes looking up as in the G. or R. Sn.)

S.W.: His soul we commend to God, who gave it.

(All drop hands, palms against thighs. No Noise.)

W.M.: The will of God is accomplished.

Omnes: S.M.I.B. *(All sit)*

W.M.: Brother orator, it devolves upon you to rehearse before us the story of our departed brother. Tell us of his good deeds, enlarge upon his virtue, kindle within us the spirit of gratitude and respect, so that we may justly mourn for that which we have lost, and strive to imitate those virtues. Freemasonry does not sit in judgement upon the departed; so let us dwell upon his divine attributes, as befitting the present proceedings.

Biographical sketch and eulogy
(Delivered from the S.E.)

Ladies, gentlemen and brethren under the sanctity of our Masonic Temple, we have assembled here this evening with our hearts grief stricken, to pay our homage and honour to the memory of our beloved M.W./R.W./V.W./W.Bro./Bro....., who left this transitory abode, to rest with the Most High, in the Grand Lodge above. He passed away on.....

Ladies and gentlemen , it has been a custom among the fraternity of Freemasons to arrange a funeral ceremony known as memorial service for the deceased brother. In conformity with this usage, we are now assembled here as Freemasons to conduct such a ceremony and to mourn the loss of this dear brother. The death of a senior Mason like him naturally makes a powerful appeal to our heart. It brings into sharp focus the uncertainty of human life and vanity of all earthly hopes and designs. It also warns us that amidst the cares and pleasures of our life, we should not forget that all of us have to face this vital truth one day. Rather, we should be ready for “our own inevitable destiny” to bid farewell to all earthly things when the call from the Great Architect comes.

Then, let us remember that a Freemason never dies when his spirit leaves his physical body. From the masonic point of view, death is only a change and is considered only as an incident in a continuing life. Since Freemasonry extends from the terrestrial to the celestial globe, a Freemason continues as a freemason even after his physical body dies. M.W./ R.W./V.W./W./ Bro., like the rest of the Brethren who went before him, has now joined the celebrated celestial Grand Lodge above.

**(BRIEF BIO-DATA OF DECEASED
BROTHER TO BE READ AT THIS POINT)**

Brethren, the death of our Brother is definitely irreparable. Let us, therefore, sympathize with members of his family in this great loss. Their loss is also our loss. *(All upstanding with Sn. of R.)*

May his Soul rest in Eternal peace

W.M.: Brethren, our recollection of our departed brother has been refreshed, and we may now ask ourselves; was he a just and perfect mason, worthy man, unwearied toiler in the vineyard, and possessed of so many virtues as to overcome his faults and short-comings? Answer these questions as masons should.

Omnes: Man judgeth not man. He, whose infinite and tender mercy passeth all comprehension, whose goodness endureth forever, has called our brother hence. Let him judge.

W.M.: May we be true and faithful, and may we live and die in love.

Omnes: S.M.I.B.

W.M.: May the Lord bless and prosper us, and may all our good intentions be crowned with success.

Omnes: S.M.I.B.

W.M.: Glory be to God in the highest; on earth peace; goodwill towards men.

Omnes: S.M.I.B. Now and forever more. Amen.

W.M.: Brethren, let us profit by the admonitions of this solemn occasion. Lay to heart, the truths to which we have listened and resolve to so walk, that when we lay down to the last sleep, it may be the privilege of the brethren to strew white flowers upon our last resting place and keep our memory as a pleasant remembrance.

W.M.: Brethren, let us sing Hymn No.27. (A.& M.) (*Recorded Hymn may be played*).

Hymn No. 27 (A. & M.)

Abide with me, fast falls the eventide,
The darkness deepens, Lord with me abide,
When other helpers fail and comforts flee,
Help of the helpless, O abide with me,

Swift to its close ebbs out life's little day,
Earth's joys grow dim, its glories pass away,
Change and decay run all around I see,
O, Thou who changeth not, abide with me.

I need Thy presence ever passing hour,
What but Thy grace can foil the tempter's power?
Who like Thyself my guide and stay can be?
Through cloud and sunshine Lord, abide with me.

I fear no foe with Thee at hand to bless,
Ills have no weight and tears no bitterness,
Where is death's sting, where, grave thy victory?
I triumph still, if Thou abide with me.

Extended Thy grace unto my closing eyes,
Shine through the gloom and point me to the skies,
Heaven's morning breaks and earth's vain shadows flee,
In life, in death, O Lord abide with me,

Amen

W.M. : Let us unite with Bro. Chap. in an Invocation to the Throne of Grace.

D. of C. : To order (Sn. of R.)

PRAYER

Chap.: As the sun sets in the West to close the day, and heralds the approach of night, so one by one we shall lie down in the darkness of the tomb, to wait in its calm repose for the time when the heavens shall pass away on a scroll, and man standing in the presence of the Infinite, shall realize the true end of his pilgrimage here below. Let this solemn ceremony be to us the symbol of remembrance of all the virtues of our departed brother and of those who have preceded us to the silent land, the token of fraternal alliance which binds us while on earth, and which we hope will finally unite us in Heaven. Amen.

Omnes: S.M.I.B.

GRAND HONOURS

(D. of C. and A.D. of C. cover Jewels and Regalia of the deceased brother.)

J.W.: His memory we cherish here.

(All extending arms full length outward and upward, hands open, palms inwards, eyes looking up as in G. of R. Sn.)

S.W.: His soul we commend to God who gave it.

(All dropping hands, palms against thighs. No Noise)

W.M.: The will of God is accomplished.

Omnes: S.M.I.B.

REVEILLE

(I.G. to give one knock on door.)

Bugler: Reveille

(D. of C. and A.D. of C. extinguish the four candles on the sides. The fifth candle at the head continues to burn. All sit)

PART III ADDRESSES

W.M.: Brother Secretary, you will now read out any messages of condolence, which have been received by the Lodge. *(Messages of condolence, received by the Lodge, are read)*

W.M.: Any brother and visitors wishing to address the Lodge may do so now. Kindly keep your comments brief, so as to give everyone a chance to speak.

(A family member and a friend may be requested to address the Lodge after the brethren have addressed the Lodge. The W.M. will address the Lodge thereafter duly acknowledging the presence of the family members and friends of the departed brother whilst paying this last tribute to departed merit after which R.G.M. and the G.M. will address the Lodge).

RESOLUTION OF SORROW

(Bro. Sec. should have an appropriately worded resolution of sorrow prepared and ready, which the brethren will pass upstanding in solemn silence and pass on to family members / friends after the toast is taken.)

CLOSING THE MEMORIAL SERVICE

W.M.: Ladies, Gentlemen and Brethren, I close the Memorial Service by Lodge..... No. *(or joint Lodges as the case may be. He then gives one knock followed by S.W. & J.W.)*

D. of C : To order with sign of reverence. *(closes Vs S.L.)*

(The National Anthem is not to be sung/played.)

Funeral Procession – Exit (See Note)

(The procession will reach the banquet hall and brethren will take their positions round the table.)

Toast in Memoriam (Optional)

The W.M. will raise a toast: In pious memory of the departed brother. *(No response from the brethren.)*

(After the toast, brethren will leave the banquet hall in a procession in single file led by M.W. The Grand Master, R.W. the R.G.M. and the W.M. and go to the robing room to disrobe.)

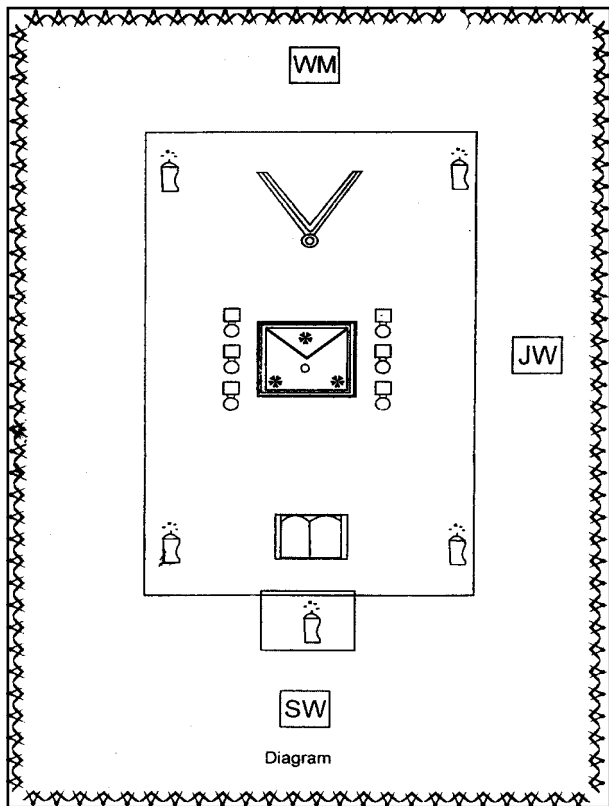



Ceremonials

Grand Lodge of India





Ceremonials

Grand Lodge of India

